

FULLVIEW ARCH DIRECT VENT GAS FIREPLACE HEATER

**Model FV34-ARCH-PF2**  
**INSTALLATION INSTRUCTIONS MANUAL**

DOCUMENT NO. FV34-ARCH-PF2-IM-0516



We recommend that our gas hearth products be installed and serviced by professionals who are certified in the U.S. by the National Fireplace Institute® (NFI) as NFI Gas Specialists.



**WARNING:** If the information in this manual is not followed exactly, a fire or explosion may result causing property damage, personal injury or loss of life.

**Do not store or use gasoline or other flammable vapors and liquids in the vicinity of this or any other appliance.**

**WHAT TO DO IF YOU SMELL GAS**

- Open windows.
- Do not touch electrical switches.
- Do not try to light any appliance.
- Extinguish any open flame.
- Do not use the phone in your building.
- Immediately call your gas supplier from a neighbor's phone. Follow the gas supplier's instructions.
- If you cannot reach your gas supplier, call the fire department.
- Installation and service must be performed by a qualified installer, service agency or the gas supplier.

**WARNING**

Do NOT use this appliance if any part has been under water. Immediately call a qualified service technician to inspect the appliance and to replace any part of the control system and any gas control, which has been under water.

**AVERTISSEMENT:** Assurez-vous de bien suivre les instructions donné dans cette notice pour réduire au minimum le risque d'incendie ou pour éviter tout dommage matériel, toute blessure ou la mort.

- Ne pas entreposer ni utiliser d'essence ni d'autres vaperurs ou liquides inflammables dans le voisinage de cet appareil ou de tout autre appareil.
- **QUE FAIRE SI VOUS SENTEZ UNE ODEUR DE GAZ:**
- Ne pas tenter d'allumer d'appareil.
- Ne touchez à aucun interrupteur. Ne pas vous servir des téléphones se trouvant dans le bâtiment où vous vous trouvez.
- Appelez immédiatement votre fournisseur de gaz depuis un voisin. Suivez les instructions du fournisseur.
- Si vous ne pouvez rejoindre le fournisseur de gaz, appelez le service des incendies.
- L'installation et service doit être exécuté par un qualifié installer, agence de service ou le fournisseur de gaz.

**INSTALLER:** Leave this manual with the appliance.  
**CONSUMER:** Retain this manual for future reference.  
**INSTALLATEUR :** Laissez cette notice avec l'appareil.  
**CONSOMMATEUR :** Conservez cette notice pour consultation ultérieure.

**⚠ WARNING**



**HOT GLASS WILL CAUSE BURNS.**  
**DO NOT TOUCH GLASS UNTIL COOLED.**  
**NEVER ALLOW CHILDREN TO TOUCH GLASS.**

**⚠ AVERTISSEMENT**



Une surface vitrée chaude peut causer des brûlures.  
 Laisser refroidir la surface vitrée avant d'y toucher.  
 Ne permettez jamais à un enfant de toucher la surface vitrée.

## INITIAL STARTUP INFORMATION AND ADVICE

**CAUTION:** Before you ignite the pilot or burners, perform the following inspections and verifications:

Check glass gasket seal. Visually inspect glass gasket, especially at the corners of the glass piece. Gasket that bulges at corners can cause improper seals between the bulges which can cause exhaust leaks and lead to acrid smell concerns. If facing materials are freshly painted or freshly polished (in cases of marble or granite), make certain that the convection blower is running at level 2 or level 3 during the first 1-1/2 hours of initial burn. After the 1-1/2 hours, turn off the convection blower and proceed with the paint curing cycle.

**INITIAL BURN CYCLE:** During the first burn cycle (approximately for 3 hours), it is normal for this appliance to emit visible smoke and some odor. The smoke generated is a mixture of paint curing, lubricating oils burn off, glass gasket adhesive curing and ceramic sealant gaskets curing. The smoke generated can trigger smoke and fire alarms. It is recommended to open all door and windows during initial cure cycle.

### **WARNING FIRE RISK- ODOR RISK**

- Install appliance on hard metal or wood surfaces extending full width and depth of this fireplace.
- An R-1 Rated Hearth Protection Pad [1-1/2" Thick Maximum] is required unless this fireplace is elevated at least 6" above floor level of the room. For every 1" this fireplace is elevated, you may reduce the hearth pad depth by 2". If this fireplace is elevated 6" or higher no hearth protection pad is required.
- Do NOT install this fireplace directly on carpeting, vinyl or any combustible material other than wood. Construct chase to all clearance specifications in manual.
- Locate and install appliance to all clearance specifications in manual.
- Verify glass gasket seal before firing unit the first time. Verify proper latching of glass frame onto unit body.

**PAINT CURING CYCLE RECOMMENDATION:** It is recommended that you run this Fireplace on maximum flame height with the Convection Blowers turned on at level 2 or level 3 for the first 1-1/2 hours. After the first 1-1/2 hours, turn OFF the Convection blowers and proceed burning on high fire for 1 cycle of 2 hours ON and 2 hours OFF to cure the paint and expel any burn off odors. Expect some visible smoke and smell during the curing cycle. Open all door and windows during initial cure cycle.

**BLOWER BREAK-IN PERIOD:** The integrated blowers in this Insert may exhibit some bearing noise and electrical static noise during the first few hours of operation. This is normal during the break-in period. The burner flames must be on during these cycles.

**PROPER PAINT TYPES APPROVED FOR USE:** Industrial Acrylic Paints, Alkyd based Paints. When selecting Paint for applications on facings, mantels, corbels or floors within 2 feet in front of a fireplace raised 6" or higher, avoid off the shelf Paints which may have modifier additives used to increase "hiding" ability, accelerate drying times and curing times. Consult with a reputable Paints and Sealants supplier and acquire Industrial Acrylic Paints or Alkyd based Paints.

**PROPER SEALANTS TYPE APPROVED FOR USE:** Heat resistant polyurethane sealants which are not damaged by prolonged exposure to raised temperatures. Many are flame resistant, meaning that they resist ignition when exposed to high temperatures and can insulate the substrate and delay damage to it. When selecting polyurethane for applications on facings, mantels, corbels or floors within 3 feet in front of a fireplace, avoid off the shelf urethane Sealants which may have modifier additives used to accelerate drying times and curing times. Consult with a reputable Paints and Sealants supplier and acquire Heat Resistant Polyurethane Sealants.

**ADDITIONAL APPLICATION CAUTIONS:** If wood used around or in front of the fireplace has been chemically cleaned or bleached prior to staining or painting, it is of the utmost importance to make certain that the cleaner or bleach does not remain in the wood substrate under the final paint or sealant applied. If any cleaner or bleach remain within the wood structure, application of heat from the fireplace, even low level heat, will cause the cleaner or bleach compounds to expand or evaporate causing separation of the paint or sealant from the wood surface and may cause peeling or bubbling of the paint or sealant.

Moisture Content of the wood substrate is also of critical importance. High moisture content wood when heated will yield evaporation of the moisture and hydraulic pressure under the paint or sealants which can lead to peeling or bubbling. Always select the lowest moisture content wood substrate. Store the wood substrate in an environment with 60-75 degrees F and 35-55% relative humidity levels for a minimum of 48 hours before applying the Paint or Sealant.

## LISTING LABEL INFORMATION

When contacting your dealer for any cleaning service or warranty service, always provide the Model Number, Serial Number and Manufacture Date. This information will expedite the warranty verification process.



DIRECT VENT GAS FIREPLACE HEATER  
(POELE AU GAZ HOMOLOGUÉ, À AÉRATION DIRECTE)  
NOT FOR USE WITH SOLID FUEL  
(NE DOIT PAS ÊTRE UTILISÉ AVEC UN COMBUSTIBLE SOLIDE)

MANUFACTURED BY (FABRIQUÉ PAR):  
JOHNSON GAS APPLIANCE CO. CEDAR RAPIDS, IOWA  
CERTIFIED FOR CANADA (HOMOLOGUÉ POUR LE CANADA)  
CONFORMS TO (CONFORME AUX): ANSI Z21.88-2014  
CERTIFIED TO (CERTIFIÉ) CAN/CGA 2.17-M91\* CSA 2.33-2014



**WARNING:** IMPROPER INSTALLATION, ADJUSTMENT, ALTERATION, SERVICE OR MAINTENANCE CAN CAUSE PROPERTY DAMAGE, PERSONAL INJURY, OR LOSS OF LIFE. REFER TO THE OWNER'S INFORMATION MANUAL PROVIDED WITH THIS APPLIANCE. INSTALLATION AND SERVICE MUST BE PERFORMED BY A QUALIFIED INSTALLER. THIS VENTED GAS FIREPLACE HEATER IS NOT FOR USE WITH AIR FILTERS. REGISTER KIT MAY BE USED. FOR USE ONLY WITH GLASS BARRIER Part no. AA-11-02462

**MISE EN GARDE:** INSTALLATION, RÉGLAGE, MODIFICATION, ENTRETIEN OU DÉPANNAGE NON APPROPRIÉS POURRONT CAUSER DES BLESSURES OU DES DOMMAGES MATÉRIELS. RÉFÉREZ-VOUS AU MANUEL DU PROPRIÉTAIRE FOURNI AVEC CET APPAREIL. POUR ASSISTANCE OU RENSEIGNEMENTS COMPLÉMENTAIRES, VEUILLEZ CONSULTER UN INSTALLATEUR EXPÉRIMENTÉ, UNE AGENCE DE DÉPANNAGE/ENTRETIEN OU VOTRE COMPAGNIE GAZIÈRE, POUR UTILISATION AVEC LES PORTES EN VERRE CERTIFIÉE L'APPAREIL SEULEMENT. NE PAS OPÉRER AVEC LE VERRIÈRE ENLEVÉ, CRAQUELURE, BRISÉ.

**WARNING:** DO NOT OPERATE THE APPLIANCE WITH GLASS FRONT REMOVED, CRACKED OR BROKEN. REPLACEMENT OF THE PANEL(S) SHOULD BE DONE BY A LICENSED OR QUALIFIED SERVICE PERSON. FOR USE WITH GLASS DOORS CERTIFIED WITH THE APPLIANCE ONLY.

**AVERTISSEMENT:** NE PAS UTILISER L'APPAREIL SI LE PANNEAU FRONTAL EN VERRE N'EST PAS EN PLACE, EST CRAQUÉ OU BRISÉ. CONFIEZ LE REMPLACEMENT DU PANNEAU À UN TECHNICIEN AGRÉÉ. SEULES DES PORTES CERTIFIÉES POUR CET APPAREIL DOIVENT ÊTRE UTILISÉES.

	<input type="checkbox"/> NATURAL GAS (GAZ NATUREL)	<input type="checkbox"/> LP GAS (GAS DE PÉTROLE) LIQUÉFIÉ (GPL)
INPUT RATING (BTR/HR) 0-2000ft (0-610m) (ENTRÉE NOMINALE)	31,500	31,500
MIN. INPUT RATING (BTU/HR) 0-2000ft (0-610m) (MINIMALE ENTRÉE NOMINALE)	8,985	12,627
ORIFICE 0-2000ft (0-610m) (ORIFICE)	FRONT #49 REAR #44	FRONT 3/64" REAR 3/64"
ORIFICE 2000-5000ft (610-1370m) (ORIFICE)	FRONT #49 REAR #44	FRONT 3/64" REAR #55"
INPUT RATING (BTU/HR) 2000-5000ft (610-1370m)	31,500	31,000
MAXIMUM OUTPUT (BTU/HR) (SORTIE MAXIMALE)	23,452	23,452
MANIFOLD PRESSURE (in. wc./kPa) (PRESSION AU COLLECTEUR)	3.5 (0.87)	10.0 (2.5)
MANIFOLD PRESSURE, LOW (in. wc./kPa) (PRESSION AU COLLECTEUR MINIMALE)	1.7 (0.42)	6.3 (1.57)
MINIMUM INLET PRESSURE (in. wc./kPa) (PRESSION D'ENTRÉE MINIMALE)	5.0 (1.24)	11.0 (2.74)

THIS APPLIANCE IS ONLY FOR USE WITH THE TYPE OF GAS INDICATED ON THE RATING PLATE AND MAY BE INSTALLED IN AN AFTERMARKET, PERMANENTLY LOCATED, MANUFACTURED HOME (USA ONLY) OR MOBILE HOME, WHERE NOT PROHIBITED BY LOCAL CODES. SEE OWNER'S MANUAL FOR DETAILS. THIS APPLIANCE IS NOT CONVERTIBLE FOR USE WITH OTHER GASES, UNLESS A CERTIFIED KIT IS USED.

CET APPAREIL DOIT ÊTRE UTILISÉ UNIQUEMENT AVEC LE TYPE DE GAZ INDIQUÉ SUR LA PLAQUE SIGNALÉTIQUE. CET APPAREIL PEUT ÊTRE INSTALLÉ DANS UNE MAISON PRÉFABRIQUÉE OU MOBILE (É.-U. SEULEMENT) INSTALLÉE À DE MEURE SI LES RÈGLEMENTS LOCAUX LE PERMETTENT. VOIR LA NOTICE DE L'UTILISATEUR POUR PLUS DE RENSEIGNEMENTS. CET APPAREIL NE PEUT PAS ÊTRE UTILISÉ AVEC D'AUTRES GAZ SAUF SI UNE TROUSSE DE CONVERSION CERTIFIÉE EST FOURNIE.

	MINIMUM CLEARANCES TO COMBUSTIBLE CONSTRUCTION	
UNIT TO FLOOR	0in. (0 mm)	GLASS EDGE TO ADJACENT SIDEWALL 16in. (406 mm)
UNIT TO ENCLOSURE SIDEWALL	½ in. (13 mm)	VENT PIPE TOP TO COMBUSTIBLES 2in. (51 mm)
UNIT TO ENCLOSURE BACK WALL	½ in. (13 mm)	VENT PIPE SIDES TO COMBUSTIBLES 1in. (0 mm)
UNIT TOP TO ENCLOSURE CEILING	1-1/2in. (38 mm)	VENT PIPE BOTTOM TO COMBUSTIBLES 1in. (0 mm)
UNIT FLOOR TO ROOM CEILING	72 in. (1830 mm)	8" MANTLE ABOVE DISCHARGE AIR OPENING 20in. (508 mm)

CAUTION: HOT WHILE IN OPERATION. DO NOT TOUCH. KEEP CHILDREN, CLOTHING, FURNITURE, AND FLAMMABLE LIQUIDS OR VAPORS AWAY.

ATTENTION: L'APPAREIL EST CHAUD LORSQU'IL FONCTIONNE. NE PAS TOUCHER L'APPAREIL. SURVEILLER LES ENFANTS. GARDER LES VÊTEMENTS, LES MEUBLES, L'ESSENCE OU AUTRES LIQUIDES À VAPEUR INFLAMMABLES LOIN DE L'APPAREIL.

ELECTRICAL RATING (COURANT NOMINAL): 120 VOLTS 60 HERTZ LESS THAN 1.5 AMPERES

DO NOT REMOVE OR COVER THIS LABEL  
VEUILLEZ A NE JAMES ENLEVER NI DISSIMULER CETTE ÉTIQUETTE

MFG. DATE:	MODEL: FV34-ARCH-PF2 SERIAL NO. WH-FV34-ARCH-
------------	---

**MENLOIA**  
AMERICA'S LUXURY FIREPLACE

65-01-000474

## **TABLE OF CONTENTS**

<b>INITIAL STARTUP INFORMATION AND ADVICE</b> .....	<b>2</b>
<b>LISTING LABEL INFORMATION</b> .....	<b>3</b>
<b>SAFETY AND WARNING INFORMATION</b> .....	<b>6</b>
<b>FV34-ARCH FEATURES - QUICK REFERENCE INFORMATION</b> .....	<b>8</b>
<b>SPECIFIC REQUIREMENTS FOR THE COMMON WEALTH OF MASSACHUSETTS</b> .....	<b>8</b>
<b>FV34-ARCH FULL VIEW GAS FIREPLACE DIMENSIONS</b> .....	<b>11</b>
<b>TECHNICAL SPECIFICATIONS FOR FV34-ARCH</b> .....	<b>11</b>
<b>CONGRATULATIONS</b> .....	<b>9</b>
<b>BUILDING PERMIT AND INSTALLATION INSPECTION APPROVAL REQUIREMENTS</b> .....	<b>9</b>
<b>GENERAL APPLIANCE SPECIFICATIONS</b> .....	<b>13</b>
<b>PLANNING THE INSTALLATION</b> .....	<b>14</b>
<b>ROUGH FRAMING DIMENSIONS</b> .....	<b>15</b>
ROUGH FRAMING DIMENSIONS.....	15
CONSTRUCTING THE APPLIANCE CHASE.....	15
<b>BACKUP DC POWER INLET PORT INSTALLATION</b> .....	<b>17</b>
<b>FRAMING DEPTH AND FINISHING GUIDES</b> .....	<b>18</b>
MAXIMUM THICKNESS OF FINISHING MATERIAL ALLOWED:.....	18
RECOMMENDED BACKING MATERIALS OVER NON-COMBUSTIBLE ZONES:.....	18
<b>SUITABLE FACING BACKER MATERIALS AND HEARTH PROTECTION MATERIALS</b> .....	<b>19</b>
<b>FINISHING MATERIALS INSTALLATION</b> .....	<b>20</b>
TILES AND FAUX ROCK.....	20
MARBLE AND GRANITE SLABS.....	20
<b>HEARTH PROTECTION PAD REQUIREMENTS</b> .....	<b>21</b>
<b>GENERAL INFORMATION</b> .....	<b>22</b>
<b>GAS SUPPLY REQUIREMENTS</b> .....	<b>23</b>
GAS SUPPLY LINE SIZING.....	23
GAS PRESSURE CHECKING REQUIREMENTS.....	23
MANUAL GAS SHUTOFF VALVE INSTALLATION REQUIREMENT.....	23
<b>GAS PRESSURE REQUIREMENTS</b> .....	<b>24</b>
<b>GENERAL INSTALLATION INSTRUCTIONS</b> .....	<b>25</b>
<b>GENERAL FLUE VENTING INSTRUCTIONS</b> .....	<b>26</b>
<b>EXTERIOR VENT LOCATIONS AND RESTRICTIONS</b> .....	<b>28</b>
<b>FLUE VENTING COMPONENTS IDENTIFICATION</b> .....	<b>29</b>
<b>FV34-ARCH MASTER FLUE VENTING REQUIREMENTS CHART</b> .....	<b>30</b>
<b>IMPORTANT VENTING CONFIGURATION NOTES</b> .....	<b>31</b>
MAXIMUM HORIZONTAL RUN.....	31
MAXIMUM VENT SYSTEM LENGTH.....	31
USING 90° ELBOWS.....	31
USING 90° ELBBOWS WHEN THE INITIAL STARTER VERTICAL SECTION IS LESS THAN 5 FEET.....	31
USING 45-DEGREE ELBOWS.....	31
<b>APPROVED VENT SYSTEMS</b> .....	<b>32</b>
<b>MINIMUM RISE (18") WITH HORIZONTAL TERMINATION</b> .....	<b>33</b>
<b>VERTICAL RISE HORIZONTAL TERMINATION</b> .....	<b>34</b>
<b>VERTICAL THROUGH-THE ROOF VENTING</b> .....	<b>36</b>
<b>VERTICAL THROUGH-THE-ROOF VENTING USING FOUR 90° ELBOWS</b> .....	<b>38</b>
<b>FV34-ARCH DOOR OPERATION CHANGE PIC TO ARCH</b> .....	<b>39</b>
TO REMOVE DOOR.....	39
TO REPLACE DOOR.....	39

**INSTALLATION CHECK OFF LIST ..... 41**

**LIGHTING CHECK OFF LIST ..... 41**

**BLOWER SYSTEM INFORMATION ..... 40**

**LOG SET INSTALLATION ..... 41**

**FLAME APPEARANCE ADJUSTMENT ..... 53**  
 AIR SHUTTER ADJUSTMENTS ..... 53

**NATURAL TO LP GAS CONVERSION INSTRUCTIONS ..... 54**  
 ORIFICE SIZES REQUIREMENT: ..... 54

**LP PRESSURE REGULATOR CONVERSION INSTRUCTIONS ..... 58**

**LP GAS PRESSURE REQUIREMENTS CHECK ALL NUMBERS ..... 59**  
 LPG PROPER INPUT RATES: ..... 59  
 LEAK TESTING REQUIREMENTS ..... 59  
 PILOT FLAME AND MAIN BURNER RELATIONSHIP VERIFICATION ..... 59  
 PILOT FLAME LENGTH ADJUSTMENT ..... 59

**GAS INPUT RATE VERICATION REQUIREMENTS CHECK NUMBERS ..... 60**

**REMOTE CONTROL TRANSMITTER FUNCTIONS ..... 61**  
 REMOTE TRANSMITTER OPERATING INSTRUCTIONS ..... 62

**TEMPERATURE INDICATOR (°F OR °C) ..... 63**

**KEY LOCK FUNCTION ..... 63**

**LOW BATTERY POWER DETECTION ..... 63**

**OPERATING DURING POWER OUTAGES ..... 63**

**“FIRST TIME” PILOT LIGHTING INSTRUCTIONS ..... 64**  
 INITIALIZING THE REMOTE CONTROL SYSTEM ..... 64

**IPI/STANDING PILOT SYSTEM INFORMATION ..... 65**  
 INTERMITTENT PILOT LIGHT AND STANDING PILOT LIGHT FEATURES ..... 65  
 SETTING TO IPI VERSUS CPI MODE: ..... 65

**REPLACEMENT PARTS ..... 66**  
 FV34-ARCH VALVE ASSEMBLY REPLACEMENT PARTS ..... 66

**FV34-ARCH GAS IGNITION SYSTEM WIRING DIAGRAM ..... 67**

**GLASS FRAME ASSEMBLY REPAIR AND REPLACEMENT CHANGE PART NUMBERS ..... 68**  
 TO REPLACE DAMAGED GLASS ..... 68

**MAINTENANCE AND DIAGNOSTICS HELPFUL HINTS CHANGE PIC ..... 69**  
 COMPONENTS LOCATION: ..... 69

**TROUBLE SHOOTING THE FV34-ARCH FIREPLACE & MAINTENANCE INFORMATION ..... 70**  
 OVER FIRING OF BURNER ..... 70  
 MAINTAINING CORRECT PILOT-FLAME, PILOT OUTAGE & RELIGHTING ..... 70  
 CLEANING VIEWING GLASS ..... 70  
 SOOTING ..... 70  
 OPERATION DURING POWER FAILURE ..... 70  
 GAS SHUTOFF PROCEDURES ..... 70

**MAINTENANCE ..... 71**  
 ANNUAL MAINTENANCE OF MENDOTA UNITS IS REQUIRED. .... 71  
 PERIODIC INSPECTIONS REQUIRED: ..... 71

**NOTES MENDOTA WARRANTY QUALIFICATION & SERVICE REFERENCE FORM ..... 72**

**MENDOTA WARRANTY QUALIFICATION & SERVICE REFERENCE FORM ..... 72**

**MENDOTA EXTENDED PROTECTION AND LIMITED WARRANTY ..... 75**

## **SAFETY AND WARNING INFORMATION**

### **FOR YOUR SAFETY**

A qualified installer, service agency, or the gas supplier must perform installation and service.

Do not store or use gasoline or other flammable vapors and liquids in the vicinity of this or any other appliance.

### **WARNING**

Do not operate this appliance with the glass removed, cracked or broken. A licensed or qualified person should do replacement of glass.

AVERTISSEMENT. Ne pas utiliser l'appareil si le panneau frontal en verre n'est pas en place, est craqué ou brisé. Confiez le remplacement du panneau à un technicien agréé.

### **WARNING**

Mendota gas fireplaces are heat producing appliances. Do not burn wood, paper or other materials in this fireplace. This fireplace is designed as a supplement heat source. It is advisable to have an alternative primary heat supply.

In the Commonwealth of Massachusetts:

- Installation must be performed by a licensed plumber or gas fitter;
- A CO detector shall be installed in the room where the appliance is installed.

**WARNING:** Improper installation, adjustment, alteration, service or maintenance can cause injury or property damage. Refer to this manual. For assistance or additional information consult a qualified installer, service agency or the gas supplier.

This appliance may be installed in an aftermarket permanently located, manufactured (mobile) home (USA Only), where not prohibited by local codes.

This appliance is only for use with the type(s) of gas indicated on the rating plate. This appliance is not convertible for use with other gases, unless a certified kit is used.

Cet appareil peut être installé dans un maison préfabriquée (mobile) déjà installée à demeure si les règlements locaux le permettent.

Cet appareil doit être utilisé uniquement avec les types de gas indiqués sur la plaque signalétique. Ne pas l'utiliser avec d'autres gas sauf si un kit de conversion certifié est installé.

The installation must conform with local codes or, in the absence of local codes, to the current National Fuel Gas Code, ANSI Z223.1 (NFPA 54) or CAN/CGA B149.1 Installation Code.

Installer l'appareil selon les codes ou règlements locaux, ou, en l'absence de tels règlements, selon les Codes d'installation CAN/CGA-B149.

***READ and UNDERSTAND*** all instructions carefully before starting the appliance. ***FAILURE TO FOLLOW*** these instructions may result in a possible fire hazard and will void the warranty.

Any safety screen or guard removed for servicing must be replaced before operating this appliance.

Tout écran ou protecteur retiré pour permettre l'entretien de l'appareil doit être remis en place avant de mettre l'appareil en marche.

### ***THIS UNIT IS NOT FOR USE WITH SOLID FUEL.***

Installation and repair should be **PERFORMED** by a qualified service person. The appliance and venting system should be **INSPECTED** before initial use and at least annually by a professional service person. More frequent cleaning may be required due to excessive lint from carpeting, bedding, material, etc. It is **IMPERATIVE** that the unit's control compartment, burners, and circulating air passageways **ARE KEPT CLEAN** to provide for adequate combustion and ventilation air.

***Always KEEP the appliance clear and free from combustible materials, gasoline, and other flammable vapors and liquids.***

**NEVER OBSTRUCT** the flow of combustion and ventilation air. Keep the front of the appliance **CLEAR** of all obstacles and materials for servicing and proper operation.

Due to high temperature, the appliance should be **LOCATED** out of traffic areas and away from furniture and draperies. En raison des températures élevées, l'appareil devrait être installé dans un endroit où il y a peu de circulation et loin du mobilier et des tentures.

Clothing or flammable material **SHOULD NOT BE PLACED** on or near the appliance.

On ne devrait pas placer de vêtements ni d'autres matières inflammables sur l'appareil ni à proximité.

Children and adults should be **ALERTED** to the hazards of high surface temperature and should **STAY AWAY** to avoid burns or clothing ignition.

Les enfants et les adultes devraient être informés des dangers que posent les températures de surface élevées et se tenir à distance afin d'éviter des brûlures ou que leurs vêtements ne s'enflamment.

Young children should be **CAREFULLY SUPERVISED** when they are in the same room as the appliance. Toddlers, young children and others may be susceptible to accidental contact burns. A physical barrier is recommended if there are at risk individuals in the house. To restrict access to a fireplace or stove, install an adjustable safety gate to keep toddlers, young children and other at risk individuals out of the room and away from hot surfaces.

“Les jeunes enfants devraient être surveillés étroitement lorsqu'ils se trouvent dans la même pièce que l'appareil. Les tout petits, les jeunes enfants ou les adultes peuvent subir des brûlures s'ils viennent en contact avec la surface chaude. Il est recommandé d'installer une barrière physique si des personnes à risques habitent la maison. Pour empêcher l'accès à un foyer ou à un poêle, installez une barrière de sécurité; cette mesure empêchera les tout petits, les jeunes enfants et toute autre personne à risque d'avoir accès à la pièce et aux surfaces chaudes.

These units **MUST** use one of the vent systems described in the Flue Venting section of this manual.

This gas fireplace and vent assembly **MUST** be vented directly to the outside and **MUST NEVER** be attached to a chimney serving a separate solid fuel-burning appliance. Each gas appliance **MUST USE** a separate vent system. Common vent systems are **PROHIBITED**.

The vent system assembly for this fireplace must be periodically examined by a qualified service agency.

If the vent-air intake system is disassembled for any reason, reinstall per the instructions provided for the initial installation.

**INSPECT** the external vent cap on regular basis to make sure that no debris is interfering with the airflow. The flow of combustion and ventilation air not to be obstructed

**DO NOT** abuse the glass door by striking the glass, slamming the door shut, etc.

Use only authorized parts and materials obtained from Johnson Gas Appliance Company when replacing defective or damaged glass.

**DO NOT USE** abrasive cleaners on the glass door assembly. **DO NOT ATTEMPT** to clean the glass door when it is hot.

Turn off the gas before servicing this appliance. It is recommended that a qualified service technician perform an appliance check-up at the beginning of each heating season.

**DO NOT place furniture or any other combustible household objects within 36 inches of the fireplace front.**

This vented gas fireplace heater is not for use with air filters”.

Foyer au gaz à évacuation.- Ne pas utiliser avec du combustible solide.

Keep burner and control compartment clean. See installation and operating instructions accompanying appliance." S'assurer que le brûleur et le compartiment des commandes sont propres. Voir les instructions d'installation et d'utilisation qui accompagnent l'appareil.

**WARNING:** Improper installation, adjustment, alteration, service or maintenance can cause injury or property damage. Refer to the owner's information manual provided with this appliance. For assistance or additional information consult a qualified installer, service agency or the gas supplier.

**L'AVERTISSEMENT:** L'installation inconvenante, ajustement, modification, service ou entretien peut causer le dommages de propriété ou blessure. Référer au manuel d'information de propriétaire fourni cet appareil. Pour l'assistance ou information supplémentaire consulte un qualifiée installateur, agence de service ou le fournisseur de gaz.

**DO NOT USE** this appliance if any part has been under water. Immediately **CALL** a qualified service technician to inspect the appliance and to replace any part of the control system and any gas control, which has been underwater.

This appliance is for use with only doors certified by Mendota. Do not use any fronts or doors with this appliance unless they are certified by Mendota and installed by a certified installer.

## **Specific Requirements for the Common Wealth of Massachusetts**

The information in this section applies to all installations performed in the Common Wealth of Massachusetts only.

- a) For all side wall horizontally vented gas fueled equipment installed in every dwelling, building or structure used in whole or in part for residential purposes and where the side wall exhaust vent termination is less than seven (7) feet above grade, the following requirements shall be satisfied:
  1. If there is no carbon monoxide detector with an alarm already installed in compliance with the most current edition of NFPA 720, NFPA 70 and the Massachusetts State Building code in the residential unit served by the side wall horizontally vented gas fueled equipment, a battery operated carbon monoxide detector with an alarm shall be installed in compliance with the most current edition of NFPA 720, NFPA 70 and the Massachusetts State Building Code.
  2. In addition to the above requirements, if there is not one already present, a carbon monoxide detector with an alarm and a battery backup shall be installed and located in accordance with the installation requirements supplied with the detector on the floor level where the gas equipment is installed. The carbon monoxide detector with an alarm shall comply with 527 CMR, ANSI/UL 2034 Standards or CSA 6.19 and the most current edition of NFPA 720. In the event that the requirements of this subdivision cannot be met at the time of the completion of the installation of the equipment, the installer shall have a period of thirty (30) days to comply with this requirement; provided, however, that during said thirty (30) day period, a battery operated carbon monoxide detector with an alarm shall be installed in compliance with the most current edition of NFPA 720, NFPA 70 and the Massachusetts State Building Code. In the event that the side wall horizontally vented gas fueled equipment is installed in a crawl space or an attic, the carbon monoxide detector may be installed on the next adjacent habitable floor level. Such detector may be a battery operated carbon monoxide detector with an alarm and shall be installed in compliance with the most current edition of NFPA 720, NFPA 70 and the Massachusetts State Building Code.
  3. A metal or plastic identification plate shall be permanently mounted to the exterior of the building at a minimum height of eight (8) feet above grade directly in line with the exhaust vent terminal for the horizontally vented gas fueled heating appliance or equipment. The sign shall read, in print size no less than one-half (1/2) inch in size, "GAS VENT DIRECTLY BELOW, KEEP CLEAR OF ALL OBSTRUCTIONS"
  4. A final inspection by the state or local gas inspector of the side wall horizontally vented equipment shall not be performed until proof is provided that the state or local electrical inspector having jurisdiction has granted a permit for installation of carbon monoxide detectors and alarms as required above.
- (b) EXEMPTIONS: The following equipment is exempt from 248 CMR 5.08(2) (a) 1 through 4:
  1. The equipment listed in Chapter 10 entitled "Equipment Not Required To Be Vented" in the most current edition of NFPA 54 as adopted by the Board; and
  2. Product Approved side wall horizontally vented gas fueled equipment installed in a room or structure separate from the dwelling, building or structure used in whole or in part for residential purposes.
- (c) When the manufacturer of Product Approved side wall horizontally vented gas equipment provides a venting system design or venting system components with the equipment, the instructions for installation of the equipment and the venting system shall include:
  1. A complete parts list for the venting system design or venting system; and
  2. Detailed instructions for the installation of the venting system design or the venting system components.
- (d) When the manufacturer of a Product Approved side wall horizontally vented gas fueled equipment does not provide the parts for venting the flue gases, but identifies "special venting systems", the following shall be satisfied:
  1. The referenced "special venting system" instructions shall be included with the appliance or equipment installation instructions; and
  2. The "special venting systems" shall be Product Approved by the Board, and the instructions for that system shall include a parts list and detailed installation instructions.
- (e) A copy of all installation instructions for all Product Approved side wall horizontally vented gas fueled equipment, all venting instructions, all parts lists for venting instructions, and/or all venting design instructions shall remain with the appliance or equipment at the completion of the installation.



## **CONGRATULATIONS**

You are the owner of a world-class heat producing gas direct vent sealed combustion fireplace.

This elegant, highly efficient Fireplace will be a constant source of comfort and fascination. It will be the focal point of beauty and interest in your home.

The Mendota Gas Fireplace is a true heating appliance incorporating the traditional aesthetics of fireplace fire viewing with the controllability and fuel efficiency of a home gas furnace. Of particular interest is the low fuel consumption and brilliant fire viewing afforded by the realistic HearthGlo wood fire-like combustion system.

Carefully read the following instructions prior to actual installation. Proper Mendota Gas Fireplace installation and operation will give you years of safe, trouble free comfort and enjoyment.

If you have any questions regarding installation or operation of your Mendota Fireplace please contact your local dealer.

### **...CAUTION...**

Due to high temperatures, the Fireplace should be located out of traffic and away from furniture and draperies. Children and adults should be alerted to the hazards of high surface temperature and should stay away to avoid burns or clothing ignition. Young children should be carefully supervised when they are in the same room as the Mendota Gas Fireplace.

Clothing or other flammable material should not be placed on or near the Fireplace.

Any safety screen or guard removed for servicing an appliance must be replaced prior to operating this appliance.

The Mendota Gas Fireplace is a powerful and efficient heating unit. It has been designed as a major source of supplemental heat. As with any mechanical appliance there can be component shut downs. It is advisable to have an alternate heat supply.

Installation, repair and any adjustments to logs or burner must be done by a qualified service person. The appliance should be inspected before use and at least annually by a professional service person. More frequent cleaning may be required due to excessive lint from carpeting, bedding material, carbon build-up, etc. It is imperative that control compartments, burners and circulating air passageways of the appliance be kept clean. The burner and pilot flames and logs should be visually checked periodically.

DO NOT use this appliance if any part has been under water or exposed to moisture corrosion. Immediately call a qualified service technician to inspect the Fireplace and replace any part of the control system and any gas control, which has been under water. DO NOT use this fireplace if the burner does not light immediately. Turn unit off and call Mendota approved service person if there is any delay in burner light off.

It is Johnson Gas Appliance Company's policy that no responsibility is assumed by the Company or by any of its employees or representatives for any damages caused by an inoperable, inadequate, or unsafe condition which is the result, either directly or indirectly, of any improper operation, installation or servicing procedures.

### **Building Permit and Installation Inspection Approval Requirements**

All installations of Mendota Fireplaces and Inserts must comply with all the requirements stated in this Installation and Operating Instructions Manual. The Dealer and/or installer must also obtain all required Building Permits and Inspection Approval from the local building inspection department or the local body having jurisdiction. In order to validate warranty coverage, Mendota may require facsimile copies of the Building Permit and Inspection Approval forms. Failure to provide adequate proof that the installation conforms to all local requirements and the requirements stated in the Installation and Operating Instructions Manual will void all applicable warranty.

**INSTALLER: THESE INSTRUCTIONS ARE TO REMAIN WITH HOMEOWNER.**

**HIGH ALTITUDE INSTALLATION INFORMATION:** Prior to installing at altitudes higher than 7500, understand the need for gas input Deration. Contact Mendota Technical Service for support.

## **FV34-ARCH FEATURES - QUICK REFERENCE INFORMATION**

**EXTERNAL DIMENSIONS:** 39-7/16" Wide X 40-7/16" High X 14-9/16" Deep

**MINIMUM FRAMING DIMENSIONS:** 40-5/8" WIDE x 40-3/4" HIGH X 14-5/8" DEEP

**GLASS SIZE:** NeoCeram Glass with non-reflective coating. Visible Glass measures 685 in<sup>2</sup> (29-1/2" W x 24-3/8" H).

**MANTEL ALLOWANCE:** 8" Deep Mantel at 20" Above Top Convection Opening

**VENT SYSTEM ALLOWANCE:** Top Vent Only. 4" exhaust and 6-5/8" combustion air intake coaxial vent pipe required. 18" Vertical Minimum with 6" max horizontal. 40 feet Vertical Maximum. 25' maximum horizontal run allowed with 5' minimum vertical starter section.

**CONTROLS:** IPI Electronic Ignition System with AC Primary Power and DC Backup Power. Accent light and Blower operate on AC Power only. Thermostatic Remote Control Transmitter with Smart Thermostat Mode included.

**BLOWER SYSTEM:** 105 CFM High Efficiency Motor Blower System. 120VAC, 2Amps. Dedicated Hot Power only. No switches, Fan Speed Controls or Light Dimmers are allowed in same circuit.

**ACCENT LIGHT SYSTEM:** Accent Light System Included and can be turned on or off or dimmed using Remote Control Transmitter.

**BURNER SYSTEM:** Dual 304 Stainless Steel Tubular burners.

**BURNER AIR SHUTTER SYSTEMS:** Externally controllable Rear Burner air shutter and Internal rotary Front Burner air shutter.

**LOG SET:** 9-piece, Premium Definition Log Set with Extreme glow and realism ember bed.

**REFRACTORY PANELS:** Premium Detailed Red Clinker Fiber Brick Panels; Black, Copper, Mocha Enamel Panel Options.

**NATURAL GAS INFORMATION:** Factory equipped for Natural Gas. 5"WC Minimum inlet pressure required. For NG applications, Front Burner Orifice Size is #49 and the Rear Burner Orifice Size is #44.

**LPG INFORMATION:** LP conversion kit #HA-106-00023 is required. 12"WC Minimum inlet pressure required. For the FV34-ARCH LPG application, both front and rear burner orifices are to be drill size 3/64". For higher altitude, adjustment to orifice size may be necessary.

# TECHNICAL SPECIFICATIONS FOR FV34-ARCH



	<u>High Fire</u>	<u>- Adjustable to -</u>	<u>Low Fire</u>
BTUH. (MODEL FV34-ARCH)	NAT. GAS	31,500	8,985
BTUH. (MODEL FV34-ARCH)	LP GAS	31,500	12,627

**NOTE: LPG CONVERSION KIT, HA-106-00023, MUST BE PURCHASED SEPARATELY TO CONVERT TO BURN LPG IN THIS FIREPLACE.**

MAIN ORIFICE [0-2000ft (610 m)]: REAR BURNER: #44 NG [3/64" L.P.] – FRONT BURNER: #49 NG [3/64" LP]  
 .....[2000-4500ft (610-1370 m)]: REAR BURNER: #44 NG [3/64" L.P.] – FRONT BURNER: #49 NG [3/64" LP]  
 OVERALL EFFICIENCY: ..... P.4 FE 74.45%  
 CO-AXIAL DIRECT VENT FLUE: ..... 4" INNER, 6-5/8" OUTER  
 TOTAL WEIGHT: ..... 220 POUNDS  
 SAFETY: ..... AGA/CECERTIFIED IPI AUTO ELECTRONIC IGNITION SYSTEM  
 ..... ACTIVATED WITH THERMOSTATIC REMOTE CONTROL.

**APPLIANCE CERTIFICATION AND TESTING AGENCY**

INTERTEK TESTING SERVICES, ICBO#AA647-4  
 Certified under ANSI Z21.88 (2014) • CSA 2-33 (2014) "Vented Gas Fireplace Heaters" not for use with solid fuel. Approved for bedroom installations and mobile homes. UL307B approved for "mobile homes, after first sale of home, not for recreational vehicles."

**GLASS SAFETY BARRIER**

A certified Glass Safety Barrier must be installed on this appliance during any use.

**GAS REQUIREMENTS**..... SUPPLY PRESSURE: GAS INLET: 1/2" N.P.T.  
 NAT. GAS: **7" W.C.** (5" W.C. MIN., 11" W.C. MAX.)  
 L.P. GAS: **11.0" W.C.** (11" W.C. MIN., 13" W.C. MAX.)

**ELECTRICAL REQUIREMENTS**..... 115 VOLT, LESS THAN 1.5 amps (for blower operation only)

**APPROVED VENT SYSTEMS**..... DURAVENT, SELKIRK, AMERIVENT, SECURITY

**MINIMUM CLEARANCES TO COMBUSTIBLE CONSTRUCTION**

UNIT TO FLOOR	0in. (0mm)	INNER GUIDE EDGE TO ADJACENT SIDEWALL	16in. (40.5 cm)
UNIT TO ENCLOSURE SIDEWALL	1/2in. (13mm)	VENT PIPE TOP TO COMBUSTIBLES	2in. (51mm)
UNIT TO ENCLOSURE BACK WALL	1/2in. (13mm)	VENT PIPE SIDES TO COMBUSTIBLES	1in. (25mm)
UNIT TOP TO ENCLOSURE CEILING	1.5 in. (38 cm)	VENT PIPE BOTTOM TO COMBUSTIBLES	1in. (25mm)
UNIT BOTTOM TO ROOM CEILING	72 in. (182.9 cm)		
8" MANTLE ABOVE DISCHARGE AIR OPENING	20 in. (508 mm)		

**MINIMUM COMBUSTIBLE ROUGH FRAMING DIMENSIONS (allow extra clearance for vent system)**

WIDTH = 40-5/8" (103.2 cm)      HEIGHT = 40-3/4" (94 cm)      DEPTH = 14-5/8" (37 cm)

THIS FIREPLACE INCLUDES A SEALED COMBUSTION SYSTEM, 9-PIECE PREMIUM CERAMIC FIBER LOG SET & COALS, FIREBRICK OR ENAMELED LINER LINED FIREBOX, NEO-CERAM GLASS, ELECTRONIC IGNITION SYSTEM, 110 CFM CONVECTION AIR BLOWER, AGA CERTIFIED SAFETY SYSTEM, ACCENT LIGHT and THERMOSTATIC REMOTE CONTROL.

**CAUTION**  
**THESE INSTRUCTIONS ARE TO REMAIN WITH THE HOMEOWNER.**

**NOTE:** This installation must conform to local codes. In the absence of local codes, you must comply with the **National Fuel Gas Code, ANSI Z223.1-latest edition** in the U.S.A. and the Natural Gas and Propane Installation Code, **CSA B149 Installation Codes** in Canada.

This appliance may be installed in an aftermarket, permanently located, manufactured home (USA only) or mobile home, where not prohibited by local codes.

This appliance is only for use with the type(s) of gas indicated on the rating plate.

**WARNING:** Do not operate this appliance with the glass removed, cracked or broken. A licensed or qualified person should do replacement of glass.

**HIGH ALTITUDE INSTALLATION INFORMATION:** Prior to installing at altitudes higher than 7500, understand the need for gas input Deration. Contact Mendota Technical Service for support.

# FV34-ARCH FULL VIEW GAS FIREPLACE DIMENSIONS

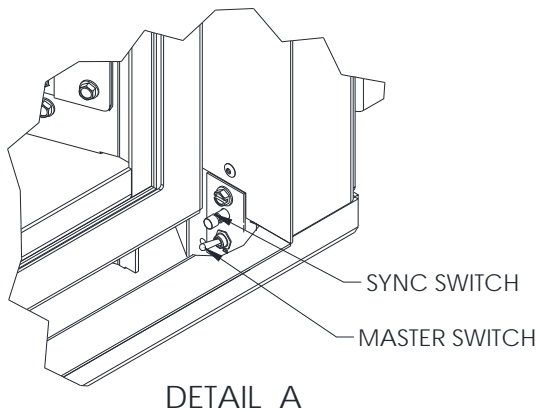
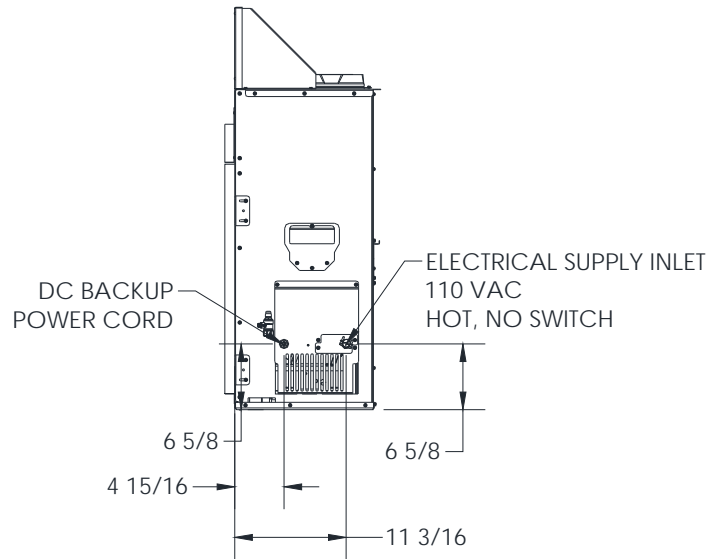
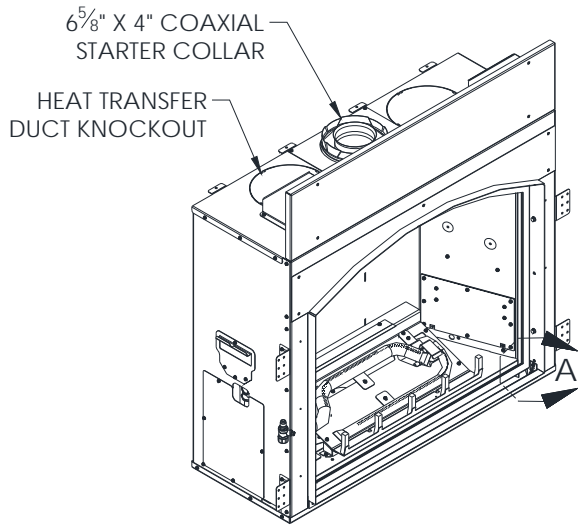
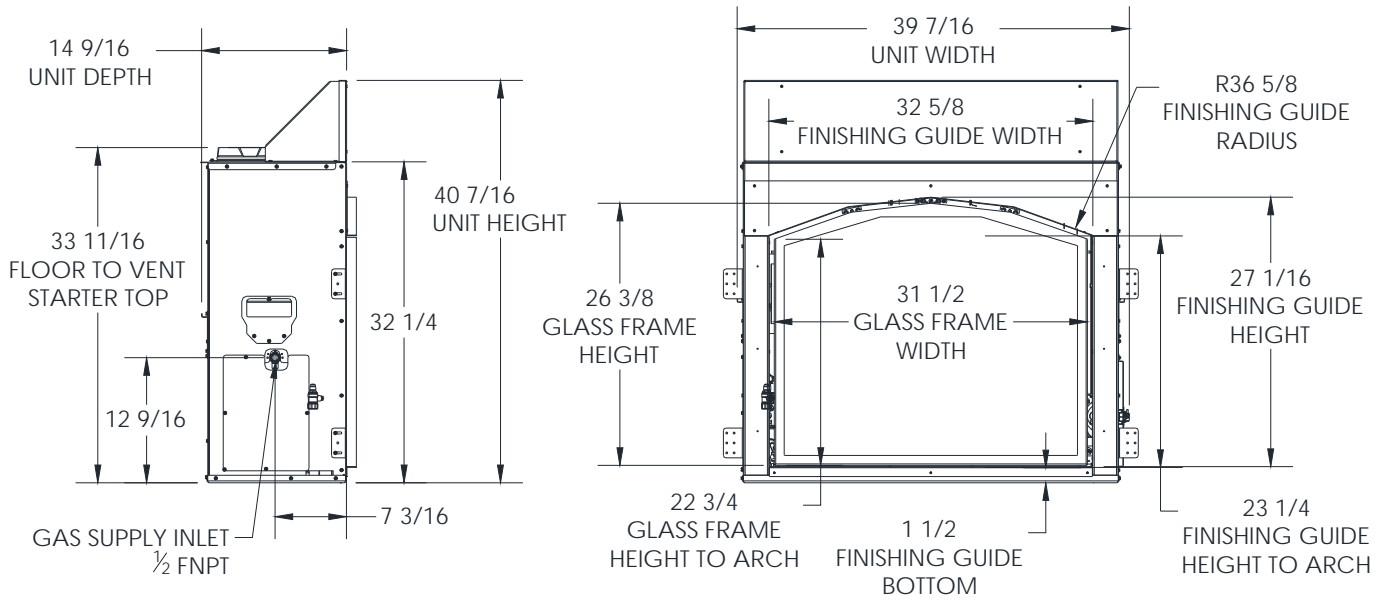

# GENERAL APPLIANCE SPECIFICATIONS

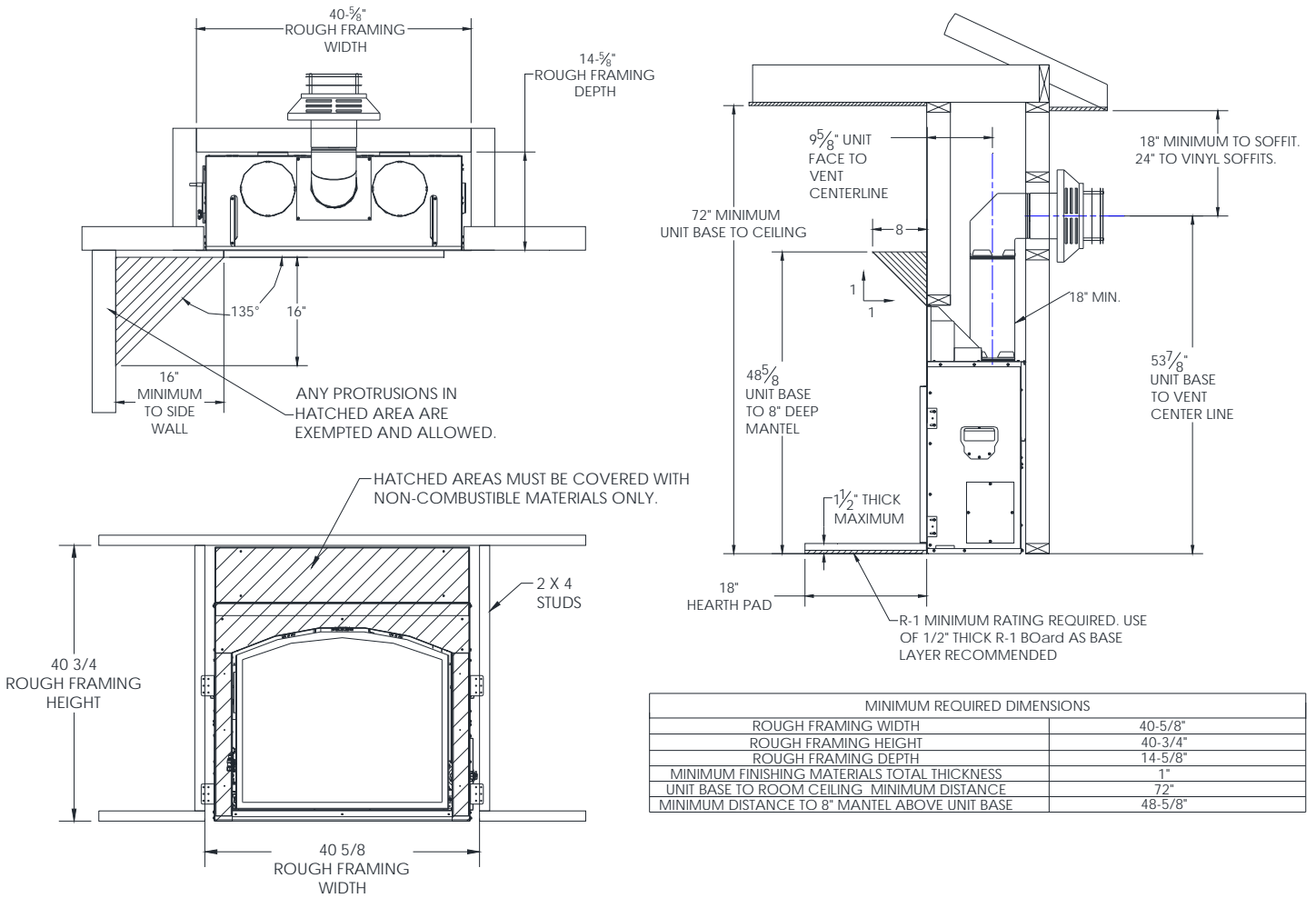

**CAUTION:** The distance from floor level to the centerline of the vent cap is given based on Simpson Duravent GS components. If using vent components of other brands do not assume that the measurement given here is applicable. Verify the distance to centerline of vencap by measuring the components you will be using.

**NOTE:** For every 1" this fireplace is raised off the floor, the non-combustible hearth protection pad may be reduced by 2". If this fireplace is raised off the floor more than 6", No hearth protection pad is required.

## **PLANNING THE INSTALLATION**

When planning on appliance installation, it is necessary to determine the following information before installing:

- Where the appliance is to be installed.
- The vent system configuration to be used.
- Gas supply piping.
- Electrical Wiring.
- Framing and finishing details.
- Hearth Protection Pad Requirements.
- Whether accessories such as a ceiling fan are desired.

### **Selecting Appliance Location**

When selecting a location for your appliance, it is important to consider the required clearances to walls.

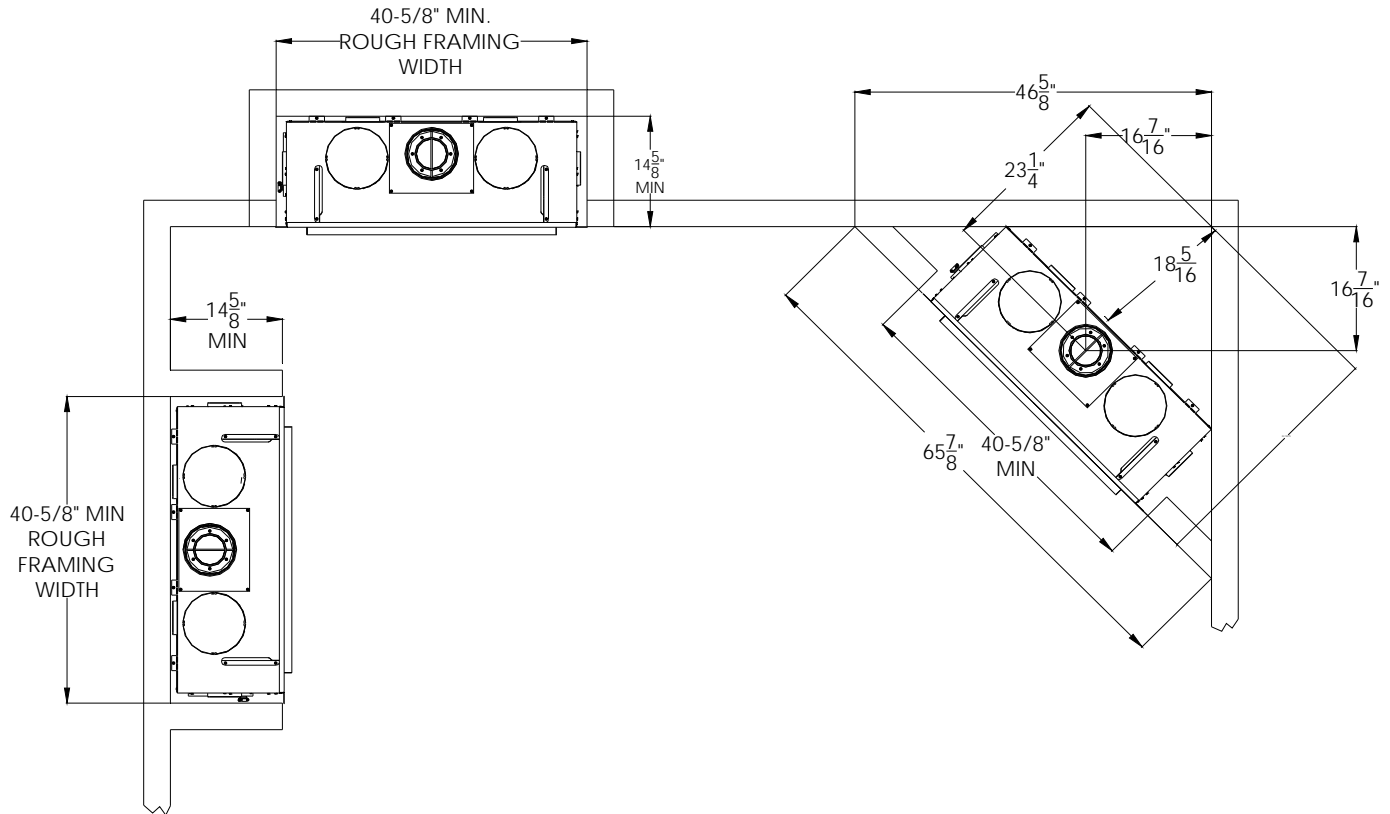

### **WARNING FIRE RISK- ODOR RISK**

- Install appliance on hard metal or wood surfaces extending full width and depth of this fireplace.
- An R-1 Rated Hearth Protection Pad [1-1/2" Thick Maximum] is required unless this fireplace is elevated at least 6" above floor level of the room. For every 1" this fireplace is elevated, you may reduce the hearth pad depth by 2". If this fireplace is elevated 6" or higher no hearth protection pad is required.
- Do NOT install this fireplace directly on carpeting, vinyl or any combustible material other than wood. Construct chase to all clearance specifications in manual.
- Locate and install appliance to all clearance specifications in manual.

## ROUGH FRAMING DIMENSIONS

### Rough Framing Dimensions

The Rough Framing Dimensions must be maintained to allow this fireplace to slide into the framing cavity.

**SPECIAL FRAMING NOTE:** On the left side of this unit, a metal box containing the ignition system protrudes outward  $\frac{1}{2}$ " and an electrical cable clamp protrudes outward  $1\frac{1}{4}$ ".

Minimum Rough Framing Dimensions		
	DESCRIPTION	DIMENSION (INCHES)
A	Width	40-5/8"
B	Height	40 3/4"
C	Depth	14-5/8" (adjust/reduce based on finishing material thickness desired)
D	Vent opening height	10"
E	Vent opening width	9"

If the fireplace is to be recessed in a cavity deeper than 14-5/8", all framing and finishing materials protruding past the front face of this fireplace must be of the NON-COMBUSTIBLE variety.

### Constructing the Appliance Chase

A chase is a vertical box-like structure built to enclose this fireplace and its vent system. Vertical vents that run on the outside of a building may be, but are not required to be, installed inside a chase.

Construction of the chase may vary with the type of building. These instructions are not substitutes for the requirements of local building codes. Local building codes **MUST** be adhered to.

Chases should be constructed in the manner of all outside walls of the home to prevent cold air drafting problems. The chase should not break the outside building envelope in any manner.

Wall, ceiling, base plate and cantilever floor of the chase should be insulated. Vapor and air infiltration barriers should be installed in the chase as per regional codes for the rest of the home. Additionally, in regions where cold air infiltration may be an issue, the inside surfaces of the chase may be sheet rocked and taped for maximum air tightness.

To further prevent drafts, the fire stops should be caulked with high temperature caulk to seal the gaps. Gas line holes and other openings should be caulked with high temp caulk or stuffed with un-faced insulation. If the appliance is being installed on a cement slab, a layer of plywood may be placed underneath this fireplace to prevent conducting cold up into the room.

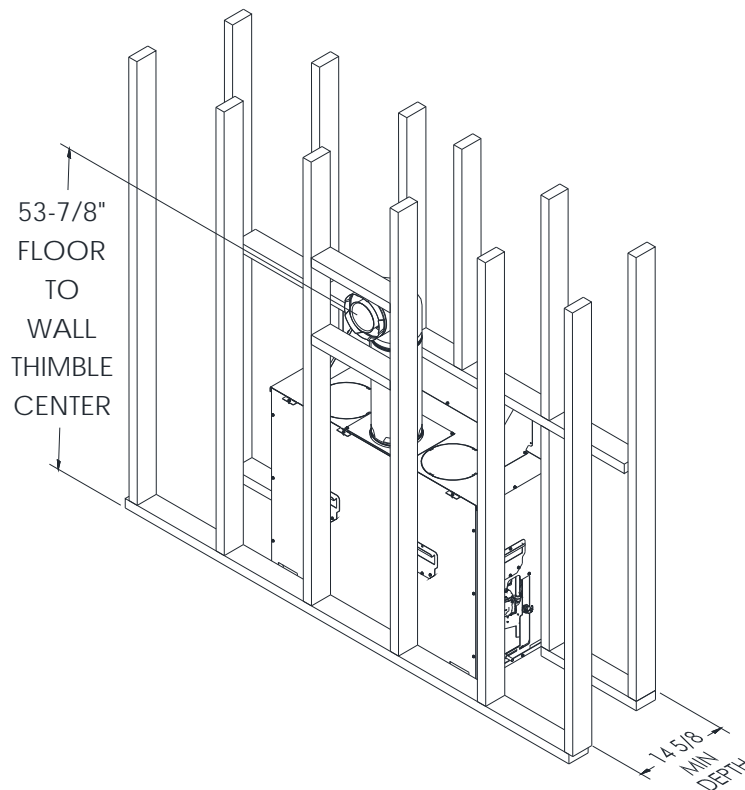

## **MANTEL CLEARANCES**

**Mantel Clearances for this fireplace may be measured from the top of the convection air opening or the floor level of this fireplace.**

The location that is referenced normally to measure mantel clearances is the Top of the Convection Air Opening. For ease, however, measure up from the floor level of this fireplace. The chart and diagram, in this page, provide all the reference dimensional information necessary in determining the distance a combustible mantel may protrude out from the face surface of this fireplace. The Chart, at right, shows the Distance from Fireplace Face the combustible mantel may protrude outward at a Distance up From Floor Level of this Fireplace.

If you prefer to take measurements from the Top of the Convection Air Opening, note that the Top of the convection air opening is 28-5/8" inches up from the floor level of this fireplace.

**WARNING:** Make proper use of this chart. Use a 1:1 Rise to Run ratio to calculate the required distance up based on your mantel depth. Do not compromise the specifications contained in this chart. Failure to adhere to proper clearances required to combustibles may cause spontaneous combustion of the mantel and may result in a fire causing property damage, personal injury or loss of life.

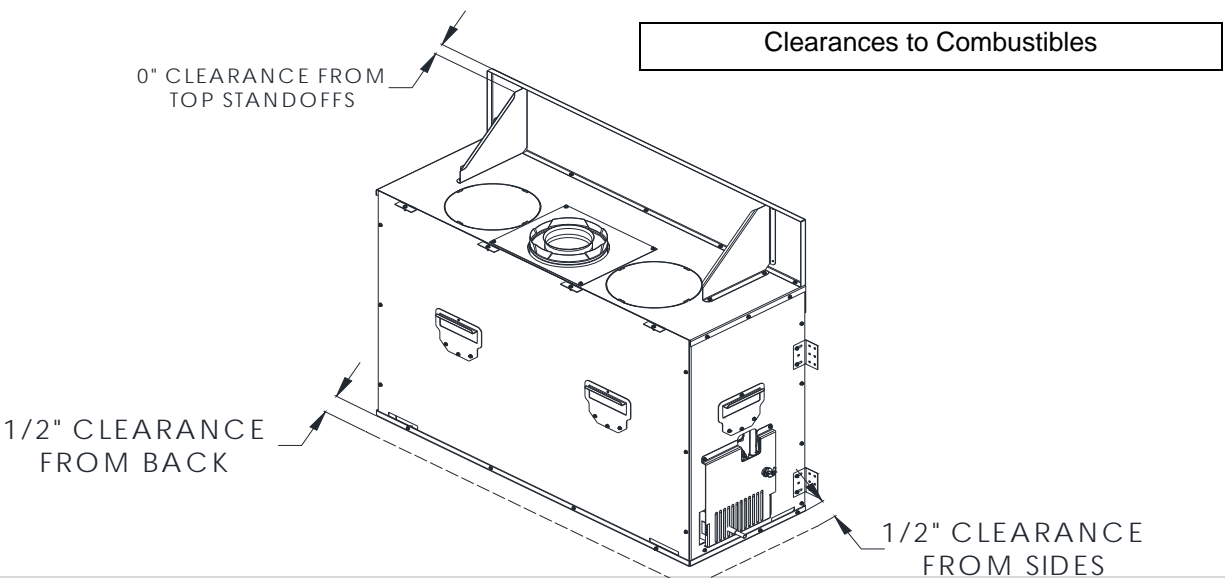
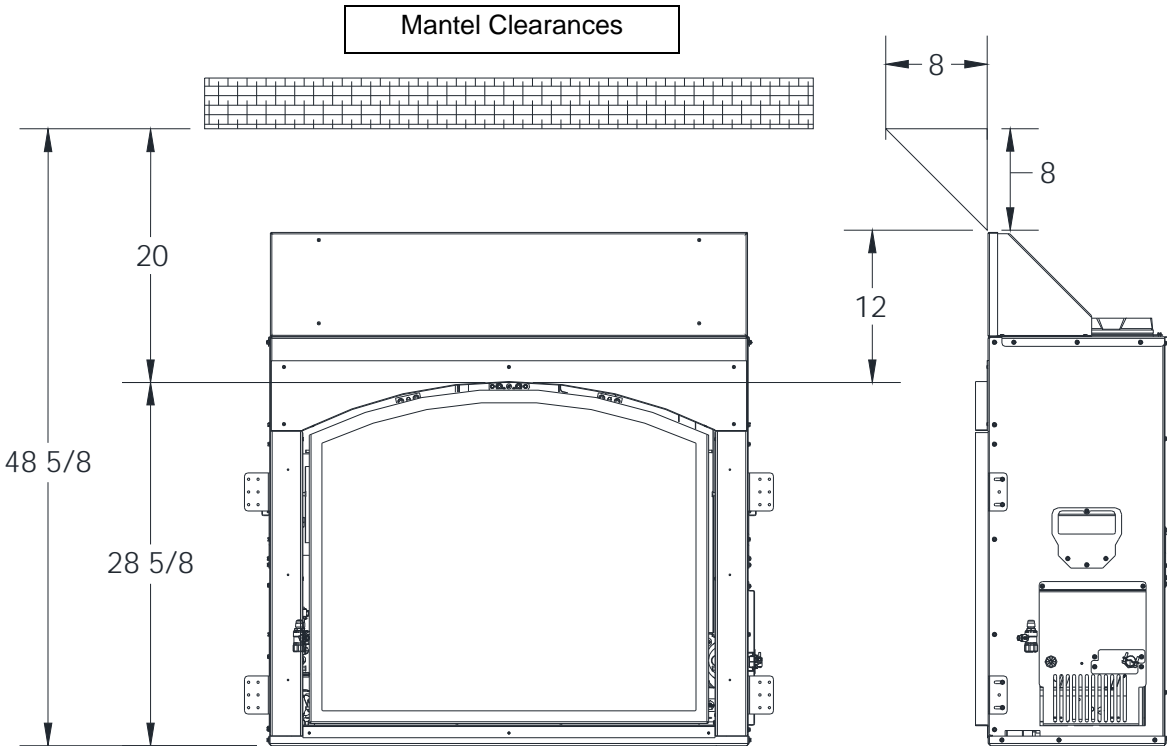



## **BACKUP DC POWER INLET PORT INSTALLATION**

Under normal conditions when AC power is available, this appliance is designed to operate on 110 VAC power. During power outages, it is designed to operate using 6 V DC backup power. This appliance is supplied with a DC power inlet harness, a single gang outlet box and two single cover plates. In addition, a 4 X AA size battery pack and a connector harness is also supplied.

**INSTALLATION:** It is important that you install the supplied harness, outlet box and cover plate on the **right side** of this appliance. The DC Power Inlet harness is 6 feet long, allowing installation of the single gang box up to 5 feet to the right of this appliance. Install the single gang box at a maximum height of 18" to the center of the box or match the mounting height of this single gang box with the height of other AC outlets that are installed in the same room as this appliance. **WARNING: DO NOT STAPLE** the 6' DC Power Inlet Harness to the wall studs.

**COVER PLATES:** Two cover plates are supplied and are White and Beige in color. If the home décor requires a different color other than the two supplied colors, obtain one from a local hardware store. Make certain that the cover you obtain is exactly the same dimensions as the ones supplied with this fireplace.

**DECAL INSTALLATION:** A notification decal (label) is supplied with this fireplace that aids in identifying the DC Power Inlet. Attach this label to cover plate once installation is complete and verified.

**INSTRUCT HOMEOWNER:** Demonstrate to the homeowner how to attach the backup DC power pack during power outages. Instruct homeowner to retain the DC battery pack and the connecting harness in a safe and secure place for use during power outages.

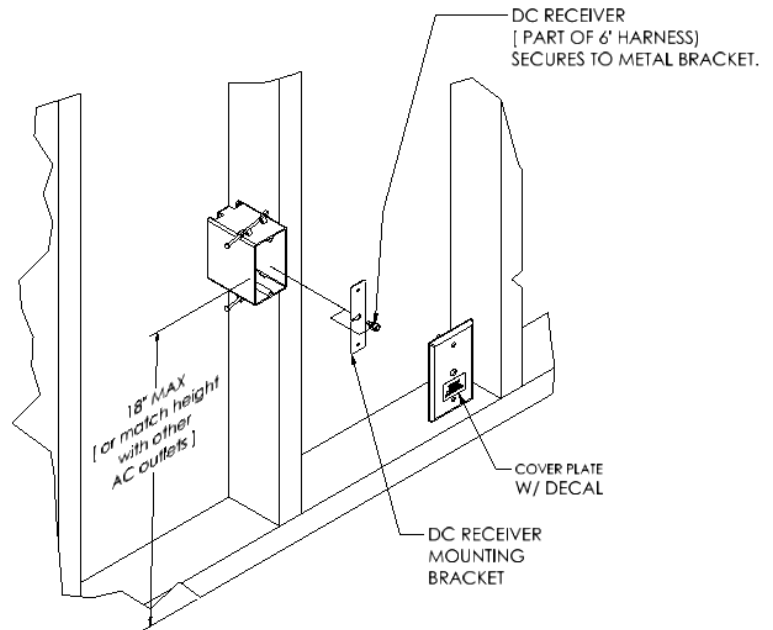

ATTACH DECAL TO COVER PLATE.

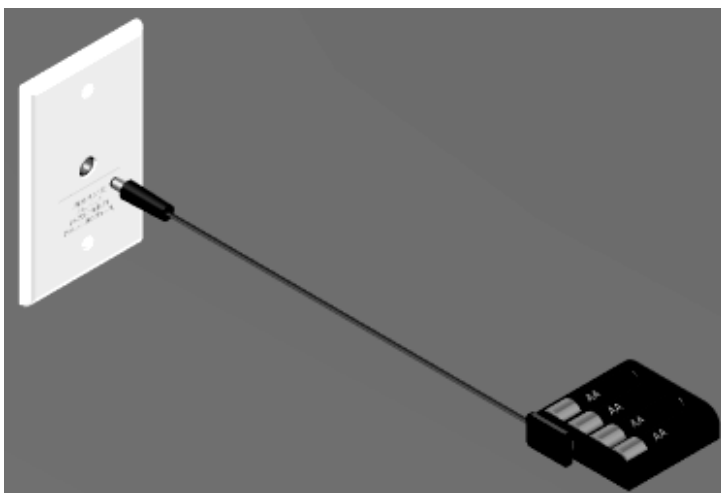

## **FRAMING DEPTH and FINISHING GUIDES**

The nominal framing depth for this fireplace is 14-5/8 inches. This is a fixed depth required for all installations, except a corner installation and for installations that use solid Granite or Marble slabs or thick natural stone materials as fascia materials. For corner installations, see General Appliance Specifications and Planning the Installation Sections.

For installing solid Granite or Marble slabs as fascia material, reduce the framing depth by 1/2" then install 1/2" thick drywall on the framing studs so that the drywall is flush with the front face of this fireplace. Install the Granite or Marble slab so that it adheres to the face of the fireplace and the drywall.

### **FINISHING GUIDE**

Only one set of Finishing Guides are supplied with this fireplace. Guides protrude out 1" from the face of this fireplace. Guides are factory secured using rivets and may be removed by drilling through the rivets using 1/8" drill bits if not needed or may be permanently left in place.

### **THICKNESS OF FINISHING MATERIAL ALLOWED:**

A maximum 2 1/2" thickness of material is allowed to be placed on top of the flat face of this fireplace and still allow all decorative Fronts options to mount and function properly. If the total thickness of finishing materials on top of the flat face of this appliance is to exceed 2 1/2" the finishing guides that come with the decorative front must be used. For more information on what finishing guides to use reference the instructions that come with the decorative front.

### **RECOMMENDED BACKING MATERIALS OVER NON-COMBUSTIBLE ZONES:**

*See R-Ratings tables provided in the next page.*

Mendota recommends the use of 1/2" thick Mineral Fiber Boards or Ceramic Boards in the non-combustible zones as backer material when you want a smooth painted finish around this fireplace. Select a backer materials which has an R-value greater than R 1.0. Follow backer material manufacturer's instructions to apply drywall compound or cement compounds to achieve the smooth finish.

For applications where you want a smooth painted plaster finish over the Mineral/Ceramic Board, cut to size and secure metal lath screen to the top surface of the Backer board using 1" long screws which penetrate the screen, Backer board and the combustible rough framing for this appliance and under the Backer Board.

For applications where you want to attach tiles or stone slabs to the Mineral/Ceramic Board, cut to size and secure metal lath screen to the top surface of the Backer board using 1" long screws which penetrate the screen, Backer board and the combustible floor structure under the Backer Board.

Proceed by applying ThinSet mortar (with no polymeric additives) which will not off gas at high temperatures and place tiles or stone slab on the ThinSet surface.

For Hearthpad applications where you want employ Marble, Granite, Stone slabs or ceramic tiles, select a base backer board which has an R-Rating greater than 1.0. Attach Marble, Granite, Stone Slabs or ceramic tiles on top of the backer board you selected.

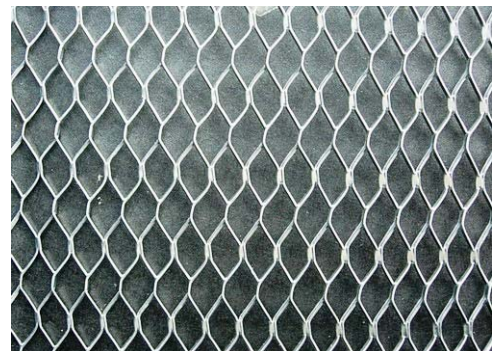

## **SUITABLE FACING BACKER MATERIALS AND HEARTH PROTECTION MATERIALS**

It is important to select the proper Facing Backer Material and proper Hearth Protection Material when installing this appliance.

### ***Definitions***

**Hearth Protection Pad:** A non-combustible protective pad installed in front of this fireplace spanning the full width of the glass door and extending into the room to a depth determined using the supplied chart based on the distance this fireplace is raised up from the floor needing protection. For Hearth Protection Pads installed in front of this Fireplace, the total R-values of all layered materials above the combustible floor must have an R-Rating of 1.0 or greater.

**Facing Backer Material:** The base layer attached to framing studs and extending over the sheet metal face of this fireplace. Backer Materials placed directly on top of this fireplace's metal face surrounding the glass frame and the convection air gaps must be of non-combustible quality. It is recommended that you use the highest R-value rated material available and suitable for your particular type of Finishing Material and the attachment method you select to attach the Finishing Material to the Facing Backer Material.

R-value is the measurement of the insulating properties of a given material at a given thickness. Below are two tables showing the R-values of common hearth and facing materials:

### **Backer Materials R-Ratings Table**

<b>R-Values of common Backer Materials</b>			
<i>Material</i>	<i>Thickness</i>	<i>R-Value</i>	<i>Note</i>
Mineral Fiber Board ( Backer 160)	1/2"	1.270	
Mineral Fiber Board (Backer 300)	1/2"	1.030	
Ceramic Board (Rescor 360)	1/2"	1.110	
Ceramic Board (Fiberfrax Duraboard LD)	1/2"	1.100	
Common Brick	2-1/4"	0.450	
Common Brick	4"	0.800	
Gypsum or Plaster Board	1/2"	0.450	
Cement Board (Durock Next Gen)	1/2"	0.390	
Cement Board (Wonderboard)	1/2"	0.260	
Cement Board (Hardibacker 500)	1/2"	0.200	
Cement Board (Hardibacker)	1/4"	0.130	

### **Finishing Materials R-Ratings Table**

<b>R-Values of common Facing Materials</b>		
<i>Material</i>	<i>Thickness</i>	<i>R-Value</i>
Cement Mortar	1/2"	0.100
Concrete	1"	0.095
Ceramic Tile	1/4"	0.020
Flagstone	1"	0.079
Granite	1"	0.083
Limestone	1"	0.153
Marble	1"	0.090
Sandstone	1"	0.079
Slate	1"	0.100

## **FINISHING MATERIALS INSTALLATION**

All finishing materials that surround this fireplace's arch profile must extend out from the face surface of this fireplace 1 inch minimum for most decorative Fronts to fit properly. A maximum finishing material thickness of 2.5" is allowed.

### **FINISHING GUIDES**

This appliance arrives with the inner finishing guides factory installed. When installing a Grace Front, Willowbrook Front or Bentley Doors on the fireplace there are two options for finishing the fireplace depending on the finishing material and desired look. The fireplace can be finished to the inner guides that come on the fireplace or the guides that come with the front kits can be installed on the fireplace and used as outer finishing guides. For more information reference the instructions that come with the front kits. If the finishing material is greater than 2.5" thick the guides that come with the fronts must be used.

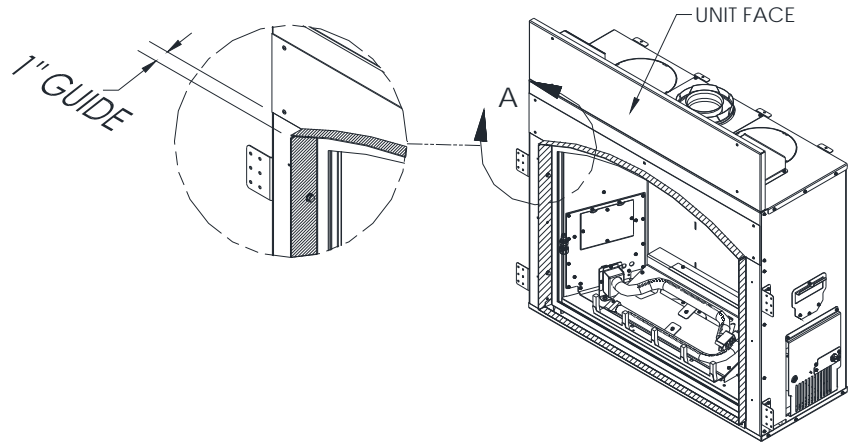

### **Tiles and Faux Rock**

If installing Tiles or Faux Rock, first install a 1/2" thick (minimum) (Backer board) over the face of the fireplace and framing members. Follow by applying Thin Set mortar (no polymer additives) using 1/4" square notched trowel on the cement board surface. Finally, install tile to reach a finish material depth of 1 inch.

### **Marble and Granite Slabs**

If installing Marble or Granite slabs as fascia materials, specify that the inner edges that will be adjacent to the Glass Door are polished. Rough Framing should be created at 14-1/8" depth with the front surface of this fireplace protruding out 1/2" from the framing surface. Install 1/2" thick drywall on framing members so that its outer surface is flush with the front face of this fireplace. Attach Marble or Granite slabs to face of unit and to drywall surface using adhesive that does not off gas when hot. Mendota recommends using High Temperature RTV Silicone 1/8" round beads in serpentine lines over the metal face of the unit to adhere the marble or Granite slabs. Never use large pools of RTV silicone. Only 1/8" round beads in spline shapes are permitted. Allow at least 24 hours or longer per manufacturer's recommendations for the RTV Silicone to cure before operating this appliance. Failure to allow adequate cure time can result in the RTV silicone oozing out of joints or the RTV can off-gas pungent odors.

In the area defined as "NONCOMBUSTIBLE ZONE" [FIGURE 7], only NONCOMBUSTIBLE MATERIALS ARE ALLOWED. Mendota Recommends the use of an R1.0 or higher rated Backer 1/2" board as base material in the non-combustible zones. DO NOT use Durock or Wonderboard. These materials breakdown when heat is applied and are not recommended.

When this fireplace is installed in a framed cavity that is 14-5/8" deep, the facing material finishing guide will protrude out into the room 1 inch. Build finishing materials to 1 inch thickness and use the built-in guides for edge alignment of fascia material. Consult section "FRAMING DEPTH and FINISHING GUIDES".

**WARNING:** The cross hatched areas labeled as "NONCOMBUSTIBLE ZONE" must be covered with noncombustible finishing materials that is 1-inch thick, minimum. DO NOT ALLOW COMBUSTIBLE FACING MATERIALS TO ENCROACH IN THIS AREA!

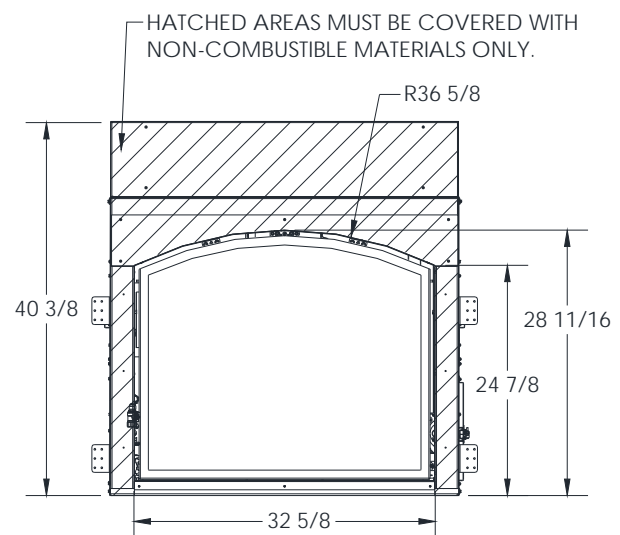

## **HEARTH PROTECTION PAD REQUIREMENTS**

Hearth Protection R Rating: MINIMUM R-1 IS REQUIRED. A 1/2" THICK (MINIMUM) Mineral/Ceramic Board with an R-Rating greater than R 1.0 is required as the backer material. You may use alternative materials that provide R-1 rating.

All hearth pads must be non-combustible (metal, brick, stone, or mineral fiberboard). **Do not use any combustible material to protect the floor in front of this fireplace. For the FV34-ARCH, the hearth protection pad must be rated at R-1 minimum AND it must extend 18 inches in front of the fireplace face if the FV34-ARCH fireplace is installed at floor level.**

To achieve this required R-rating, employ 1/2" thick Mineral/Ceramic Board as the base substrate on top of the combustible floor construction or combustible raised hearth structure before you place additional finishing materials or natural stone products to achieve an R-1.0 minimum rating.

For applications where you want to attach tiles or stone slabs to the Mineral/Ceramic Board follow the instructions supplied by the board manufacturer..

### **Hearth Pad Guide- [Usage and Removal]**

This fireplace is shipped with a Hearth Pad Guide Installed. The purpose of the Hearth Pad Guide is to limit the height of the Hearth Pad during installations and to provide a guiding edge for the finishing material thickness conformity. **DO NOT** build a Hearth pad that is more than 1-1/2" thick. Doing so will not allow installation of decorative fronts on this fireplace. Do not remove any finishing guides installed on this appliance unless you are replacing them with metallic tile edging or are installing polished stone facing such as marble or granite.

This fireplace may be installed in an elevated position by created an elevated deck and an appropriate framed enclosure.

NOTE: This fireplace may be elevated but **MUST** allow a minimum of 72" distance between this fireplace's floor level and the ceiling of the room.

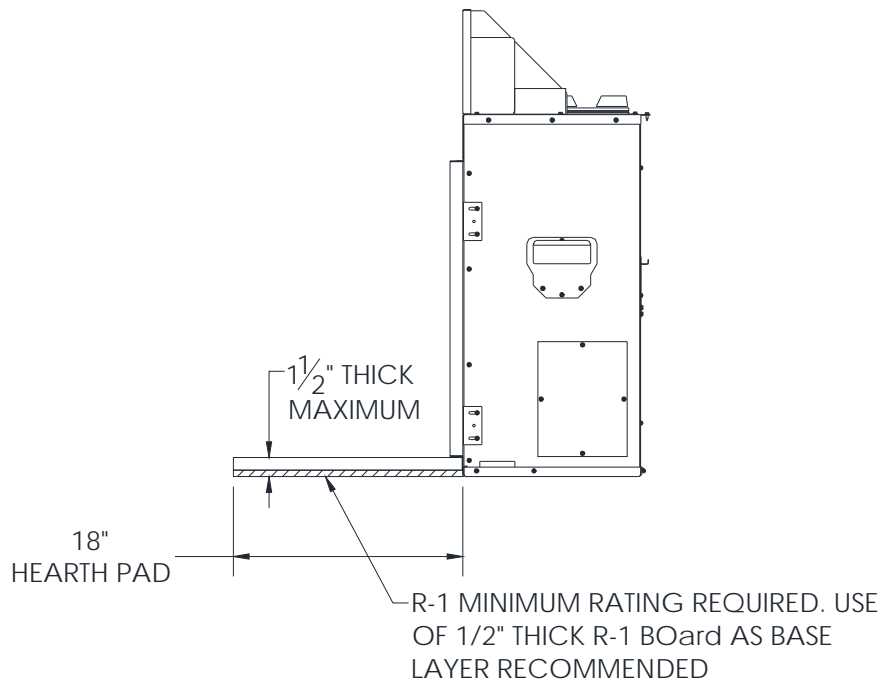

**NOTE: For every 1" this fireplace is raised off the floor, the non-combustible hearth protection pad may be reduced by 2". If this fireplace is raised off the floor more than 6", No hearth protection pad is required.**

## **GENERAL INFORMATION**

Your Mendota Gas Fireplace has a state-of-the-art co-axial direct vent, sealed combustion system. This advanced and highly efficient system brings in outside air for combustion, has a separate exhaust vent and efficiently heats and re-circulates room air. The Mendota system maintains high air quality, maximizes efficiency and assures proper operation in today's "air-tight" homes.

### **SAFETY AND STRUCTURAL CONCERNS:**

This Fireplace must be installed and serviced by a Mendota approved serviceperson. Any adjustments to burner, pilot, logs or coal bed must be made by a Mendota approved service person. If pilot goes out, always wait five (5) minutes before attempting to relight pilot.

### **VENTING REQUIREMENTS:**

This Mendota Fireplace can be vented using many available LISTED DIRECT VENT coaxial pipe (4"X 6-5/8") off the top. *Approved brands of vent components include DuraVent, Amerivent, ICC, Selkirk and Security vent pipes and venting components.* Closely follow venting locations, directions and requirements. Observe the restrictions relating to vent position on exterior of home. Be sure all vent pipe sections are fully twist-locked and leak-proof. Be sure 1000° Silicate Stove Sealant is used on the inner pipe joints of all Simpson DuraVent pipe components and all adjustable pipe sections.

The Mendota Direct Vent Fireplace may be placed within 16 inches of adjacent sidewalls. The fireplace may be placed directly on concrete or wood flooring. If the appliance is to be installed on carpeting, vinyl or other combustible material other than wood flooring, the appliance shall be installed on a metal or wood panel extending the full width and depth of the appliance. An 8" combustible mantel may be installed at a minimum of 12" above the top of the heat outlet (36-1/16") up from the floor level of this fireplace) and no more than 8" out from wall at that height. Non-combustible (marble, brick, stone, etc.) mantels can be installed at any desired height above the top convection air opening. Combustible Mantels of any depth with a sheet metal protector plate in its under-side may only be installed outside the "NON-COMBUSTIBLE ZONE" above the top convection air opening.

Never block off convection air openings or paths. Always use Mendota decorative fronts and Mendota approved vent systems and vent caps.

A non-combustible hearth protector with a total insulation rating of R-1 is required when installing this fireplace directly on the floor and must extend a minimum of 18" in front of the fireplace. For every 1 inch the fireplace is raised off the floor, the depth of the hearth protector may be reduced by 2 inches. If fireplace is raised off the floor 6" or more, no hearth protector is required.

### **HEATING PERFORMANCE:**

With its high heat output this Mendota Fireplace will heat a large area of your home if located properly to maximize heat/ air circulation. Air movement options for maximizing heat circulation that can be considered are the continuous operation of central heating furnace blowers or ceiling fans. **The most efficient method for overall heat distribution within a single room is a ceiling fan.** The heat output of the Fireplace can be reduced to a low 9,000 BTUH by turning off the Rear Burner and reducing flame height using the remote control. Blower can be turned down or turned off to reduce heat distribution.

### **AESTHETIC CONSIDERATIONS:**

Burning or static fireplaces are a major aesthetic focus in any room. Locate your gas fireplace as you would a television set. The Mendota Hearth Gas Fireplace will be a continuing source of comfort and fascination. Corner installations will afford you the greatest potential for viewing in many rooms. We suggest installing this Mendota Fireplace a minimum of 12 inches above the floor by utilizing an elevated hearth. This fireplace may be installed in an elevated position as long as 72 in. minimum distance is provided between the floor level of this fireplace and the room's ceiling surface.

### **ELECTRICAL REQUIREMENTS:**

Electronic Ignition System, Dual Blowers and an Accent Light system are included in this Mendota Direct Vent Fireplace. These devices require constant electrical power except during power outages. A 115-volt electrical service must be supplied at the fireplace location at the time of installation, on the right side of this fireplace. It must be electrically grounded in accordance with local codes, or in their absence, with the current edition of the National Electric Code ANSI/NFPA 70. Use of a wall switch control in the power supplied to this fireplace is NOT allowed.

Thermostatic function is included in the Remote Control Transmitter. Therefore, no Thermostat wire is required.

### **MANUAL GAS SHUTOFF VALVE INSTALLATION REQUIREMENT**

A manual Shutoff Ball valve is factory installed in the appliance and is accessible through the air gap on the left of the glass frame. Use the glass latch tool to operate the Shutoff Ball valve. If local building codes require, obtain an external Wall Mounted Manual Gas Shutoff Valve approved per local gas plumbing codes and install per local gas plumbing codes in the specified location.

## **GAS SUPPLY REQUIREMENTS**

Correct gas pressure and proper gas supply line sizing is imperative to the successful performance of your Mendota gas fireplace. Be sure the gas supplier or plumber carefully checks for correct gas pressure and gas line sizing when installing the fireplace.

- It is critical to carefully check for gas leaks when hooking up the fireplace -- check with soap & water solution.
- Be sure to install "approved" flex gas line with brass-to-brass fittings to prevent gas leaks at connections.
- Gas supply piping must include a drip leg to eliminate the possibility of contaminants entering the gas train.
- Adhere strictly to local and national codes for entire installation.
- Correct gas pressure and proper gas supply line sizing is required.

### **GAS SUPPLY LINE SIZING**

This Mendota Gas Fireplace comes equipped with a 1/2" N.P.T. Female inlet. Gas supply piping must enter the Fireplace cabinet on the left side.

An approved manual shut-off ball valve, if required by local codes, must be installed at an accessible location. The appliance and its individual shut-off valve must be disconnected from the gas supply piping system during any pressure testing of that system at test pressures in excess of 1/2 PSIG (3.5 kPa).

The appliance must be isolated from the gas supply piping system by closing its manual shut-off ball valve during any pressure testing of the gas supply piping system at test pressures equal to or less than 1/2 PSIG (3.5 kPa).

A proper gas line diameter must be selected to run from the supply regulator to the Fireplace. Refer to the following table for proper gas pipe diameters. Strictly adhere to the correct pipe sizes.

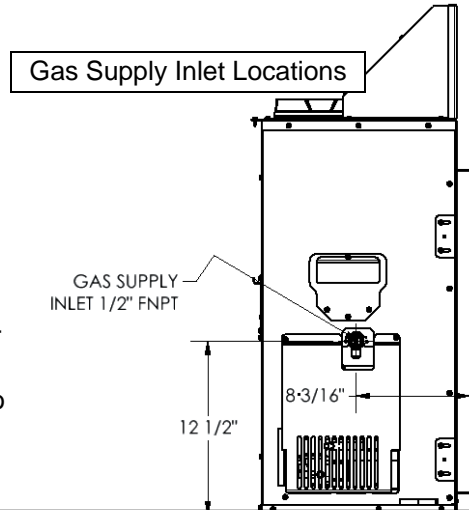

**WARNING:** Never use any type of pipe thread sealants or compounds on the seats of flare or compression connections.

PIPE LENGTH (FEET)	SCHEDULE 40 PIPE INSIDE DIA.		TUBING, TYPE L OUTSIDE DIA.	
	NAT.	L.P.	NAT.	L.P.
0-10	1/2" (1.3 cm)	3/8" (1.0 cm)	1/2" (1.3 cm)	3/8" (1.0 cm)
10-40	1/2" (1.3 cm)	1/2" (1.3 cm)	5/8" (1.6 cm)	1/2" (1.3 cm)
40-100	1/2" (1.3 cm)	1/2" (1.3 cm)	3/4" (2.0 cm)	1/2" (1.3 cm)
100-150	3/4" (2.0 cm)	1/2" (1.3 cm)	7/8" (2.3 cm)	5/8" (1.6 cm)
150-200	3/4" (2.0 cm)	1/2" (1.3 cm)	7/8" (2.3 cm)	3/4" (2.0 cm)

**NOTE:** Some areas allow coated stainless steel (CSST), copper tubing or galvanized pipe - check with local approval agencies and codes. **NEVER** use plastic pipe.

### **GAS PRESSURE CHECKING REQUIREMENTS**

Inlet and manifold gas pressure checking taps are located on gas valve. Perform inlet and outlet pressure tests before completing the facing installation. Remove valve access cover box on left side of fireplace to access the gas valve and all control components.

A qualified installer shall take pressure measurements at these ports to verify and set the correct inlet gas pressures during initial installation. Outlet gas pressures are factory-set and cannot be field adjusted.

**NOTE:** Check for gas leaks with soap and water solution on all factory joints and field installed joints during first firing of this appliance.

### **MANUAL GAS SHUTOFF VALVE INSTALLATION REQUIREMENT**

A manual Shutoff Ball valve is factory installed in the appliance and is accessible through the air gap on the left of the glass frame. Use the glass latch tool to operate the Shutoff Ball valve. If local building codes require, obtain an external Wall Mounted Manual Gas Shutoff Valve approved per local gas plumbing codes and install per local gas plumbing codes in the specified location.

## GAS PRESSURE REQUIREMENTS

One of the main causes of operating problems with gas appliances can be improper gas pressure!

Problems such as changes in flame color or configuration, gas pilot or burner outages, intermittent operation, changes in heat output, excessive burner noise, etc. are nearly always the result of changes in gas pressure or improper gas pressure at the time of the installation. The most important item to check during initial installation and the first thing to check when problems occur are the input and output gas pressures!

Gas is normally supplied to a residence at 1/2 PSI (13" - 15" W.C.) (3 KPA). A pressure regulator is then placed outside the residence, near the gas meter, which drops this pressure to 7" W.C. (1.8 KPA) (Nat. Gas). This "inches to inches" regulator is of adequate capacity to service the gas appliances (such as dryer, furnace, etc.). If this regulator's capacity is not sufficient to add the Gas Fireplace, an additional "inches to inches" regulator must be installed for the Fireplace.

**EXCEPTION:** Some codes allow 2-PSI (1.4KPA) supplies to enter the residence, in which case "pounds to inches" regulators are used.

The following table provides information on correct gas pressure requirements. Be sure your gas supplier or plumber carefully follows this table.

### GAS PRESSURE REQUIREMENTS

	DESIRED INLET PRESSURE	MINIMUM INLET PRESSURE	MAXIMUM INLET PRESSURE	MANIFOLD OUTLET PRESSURE	AIR SHUTTER POSITION*
NATURAL GAS	7.0" W.C. (1.75 kPa)	5.0" W.C. (1.12 kPa)	11" W.C. (2.61 kPa)	3.5" W.C. (0.87 kPa)	0 - 1/8 " OPEN (3 mm)
L.P. GAS	11.0" W.C. (2.75 kPa)	11" W.C. (2.75 kPa)	13.0" W.C. (3.24 kPa)	10.0" W.C. (2.5 kPa)	1/4" OPEN MIN. (5 mm)

**NOTE:** For altitudes above 2,000 feet some variations in air shutter settings may be required.

Manifold pressure must be taken at the "OUTPUT PRESSURE" tap and inlet pressure at the "INLET PRESSURE" tap **with the burner operating** by a qualified installer. Perform pressure tests prior to installing fascia material around this fireplace.

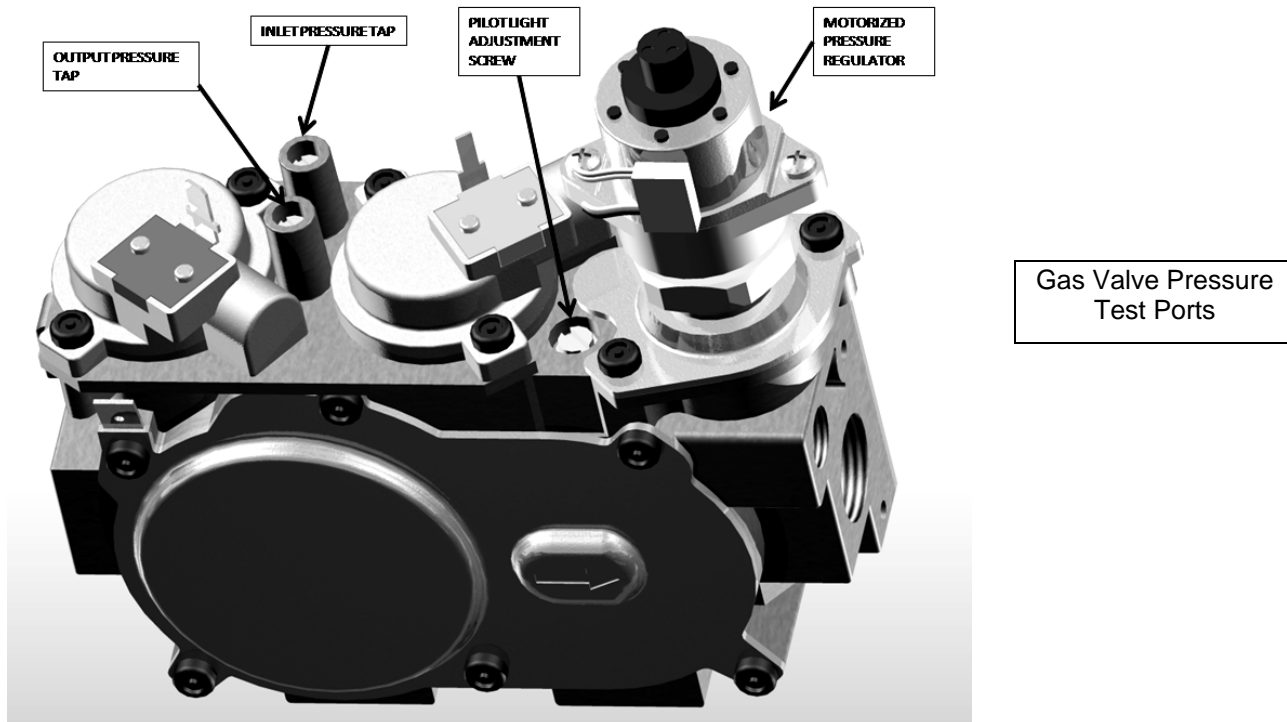



## **GENERAL INSTALLATION INSTRUCTIONS**

**CAUTION:** Each installation must conform to all local, state and national codes. Refer to the national fuel gas code and local zoning and code authorities for details on installation requirements. The Mendota Fireplace must be vented to the outside in accordance with the latest edition of the National Fuel Gas Code. In the absence of local codes, the installation must conform to the most current edition of the National Fuel Gas Code ANSI Z223.1, also known as NFPA 54. NOTE: The Mendota FV34-ARCH Fireplace is approved for mobile home and bedroom installations.

**CAUTION:** The Mendota FV34-ARCH Fireplace may be installed in a manufactured (mobile) home after the first sale of the home. Manufactured home (mobile home) installation must conform with the Manufactured Home Construction and Safety Standard, Title 24 CFR, Part 3280, or, when such a standard is not applicable, the Standard for Manufactured Home Installations, ANSI A225.1/NFPA 501A, or CSA Z240.4-Gas Equipped Mobile Housing. Consult your local building official. Note: For mobile home installations unit must be bolted to the floor and properly grounded.

**The FV34-ARCH Fireplace must be installed by a qualified service person.**

### **HIGH ALTITUDE INSTALLATION INFORMATION**

Prior to installing at altitudes greater than 7500, please contact the Mendota technical service department for specific venting requirements and venting restrictions.

1. After selection of the desired fireplace location, prepare the rough opening using framing dimensions on page 10. Be sure to also prepare opening to allow for co-axial vent).
2. Check to make certain all venting requirements and locations are being followed.
3. This Fireplace is designed for installation into rough framing. **NOTE:** FRAMING MATERIAL ABOVE FIREPLACE **MUST MAINTAIN CORRECT CLEARANCE TO FIREPLACE AND VENT PIPES.**

**WARNING: One-inch clearance to sides & below and 2 inches clearance on top of horizontal vent sections and elbows are required.**

4. NOTE: A removable panel in the enclosure for future visual inspection of flue connection is recommended.
5. Have an electrician install a 115-Volt supply to the junction box on lower left side of the fireplace cabinet. Connect wires using wire nuts. Make sure the grounding wires are properly connected and that the installation conforms to all local and national wiring codes.
6. Have gas supplier or qualified plumber install gas supply line to fireplace and connect to the ½" female connector. Be sure gas and plumbing instructions (see Page 23 and 24) and all local and national codes are carefully followed.

**IMPORTANT:** Any safety screen, guard, glass, grill etc. removed for servicing this fireplace must be replaced prior to operating this fireplace.

### **BLOWER OPERATION**

The blower output can be regulated with the remote (included).

NOTE: There will be a time delay in blower operation during "heat-up" (5 min.) and extended blower operation during "cool-down" of unit (12-1/2 min.) in Thermostat mode.

### **OPERATION DURING POWER OUTAGES**

The fireplace is designed to operate during power outages on back-up batteries. The blower and Accent Light will not operate during the power outage.

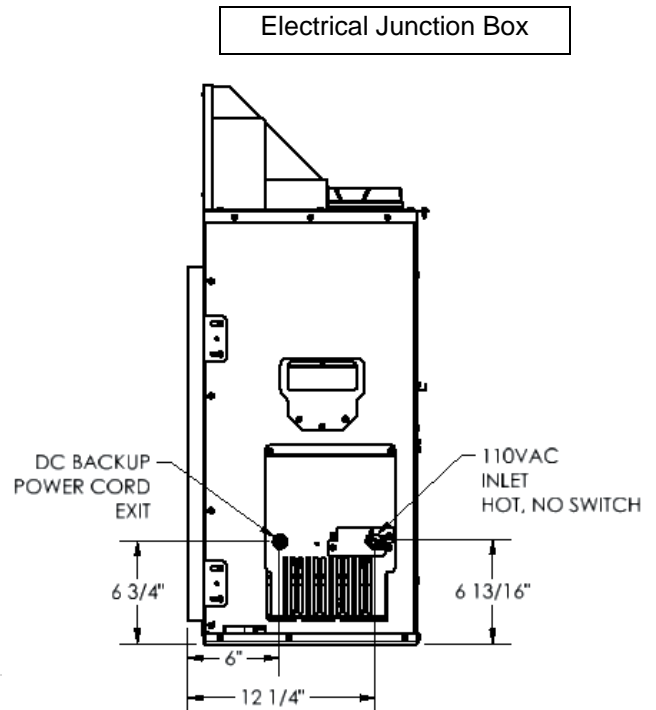

## NOTES

## **GENERAL FLUE VENTING INSTRUCTIONS**

The Mendota Fireplace must be vented using the Mendota approved vent system components. Approved brands of vent components include DuraVent, Amerivent, ICC, Selkirk and Security vent pipes and venting components. All warranties will be voided and serious fire, health or other safety hazards may result from any of the following actions: Installation by unauthorized personnel; installation of any damaged component; unauthorized modification of vent system; installation of any components not approved by Mendota; failure to meet all clearance requirements; failure to properly twist-lock and positively seal all components. Consult local building codes before beginning the installation.

**WARNING:** Always maintain required clearances (air spaces) to combustibles to prevent a fire hazard. Do not fill air spaces with insulation. Check installation instructions for minimum clearance requirements between the outer walls of the vent pipe and nearby combustible surfaces. Be sure to check the vent termination clearance requirements from decks, windows, soffit, gas regulators, air supply inlets, and public walkways, as specified in these installation instructions and local building codes.

**SAFETY PRECAUTIONS FOR THE INSTALLER:** 1) Wear gloves and safety glasses for protection; 2) Exercise extreme caution when using ladders or on rooftops; and 3) Be aware of electrical wiring locations in walls and ceilings.

This gas appliance and vent system must be vented directly to the outside of the building, and never attached to a chimney serving another solid fuel or gas burning appliance. Each direct vent gas appliance must have its own separate vent system. Common vent systems are prohibited.

To assure proper venting performance of this high-performance Mendota Direct Vent Fireplace, it is critical that all brands of vent pipe sections are sealed tightly and leak-proof. This means that all pipe sections must be carefully rotated into the fully "twist-locked" position.

**We strongly recommend that fixed length pipe sections be used in place of telescoping sections whenever possible.**

**Note:** When using vent pipe and components that do not incorporate a fiberglass or graphite gasket at the inner exhaust tube joints, you must use Milpak 1000F silicate stove sealant (#65-06-00909). Aluminum foil tape may be used on the outer (air intake) pipe joint but is not mandatory. Local Codes may vary. Contact your dealer for proper materials.

Do not separate telescoping sections. They must be used as complete assemblies.

### **COMPONENT "TWIST-LOCK" CONNECTION PROCEDURE**

DuraVent and American Metals pipe and fittings are designed with special twist-lock connections. Twist-lock procedure is as follows: four (4) indentations, located on the female ends of pipes and fittings are designed to slide straight in to the male ends of the adjacent pipes and fittings, by orienting the four pipe indentations so that they match and slide into the four entry slots on the male ends.

Push the pipe sections completely together then twist-lock one section clockwise, approximately  $\frac{1}{4}$  turn until the two sections are fully locked. The female locking lugs will not be visible from the outside on the black pipe or fittings. They may be located by examining inside of the female ends.

### **HIGH ALTITUDE INSTALLATION INFORMATION**

Prior to installing at altitudes higher than 7500, please contact the Mendota technical service department for specific venting requirements and venting restrictions.

**WARNING:** Always Use Heat Shield (#Aa-11-00458) When Exterior Wall Covering Is Made Of Vinyl, Wood Or Other Combustible Materials. Heat Shield (#AA-11-00458) Or An Equivalent Heat Shield Shall Be Installed. Heat Shield (#AA-11-00458) Is Available For Order Directly From Mendota Fireplaces.

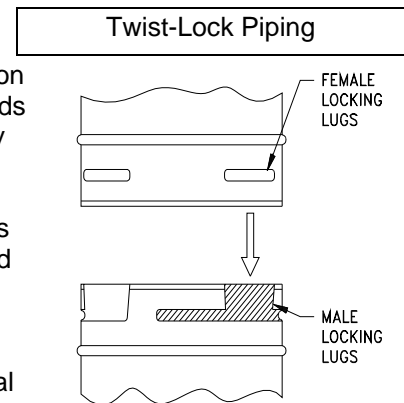

HEAT SHIELD #AA-11-00458

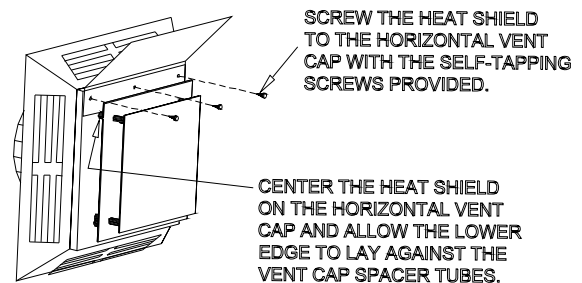

# EXTERIOR VENT LOCATIONS AND RESTRICTIONS

Exterior Vent

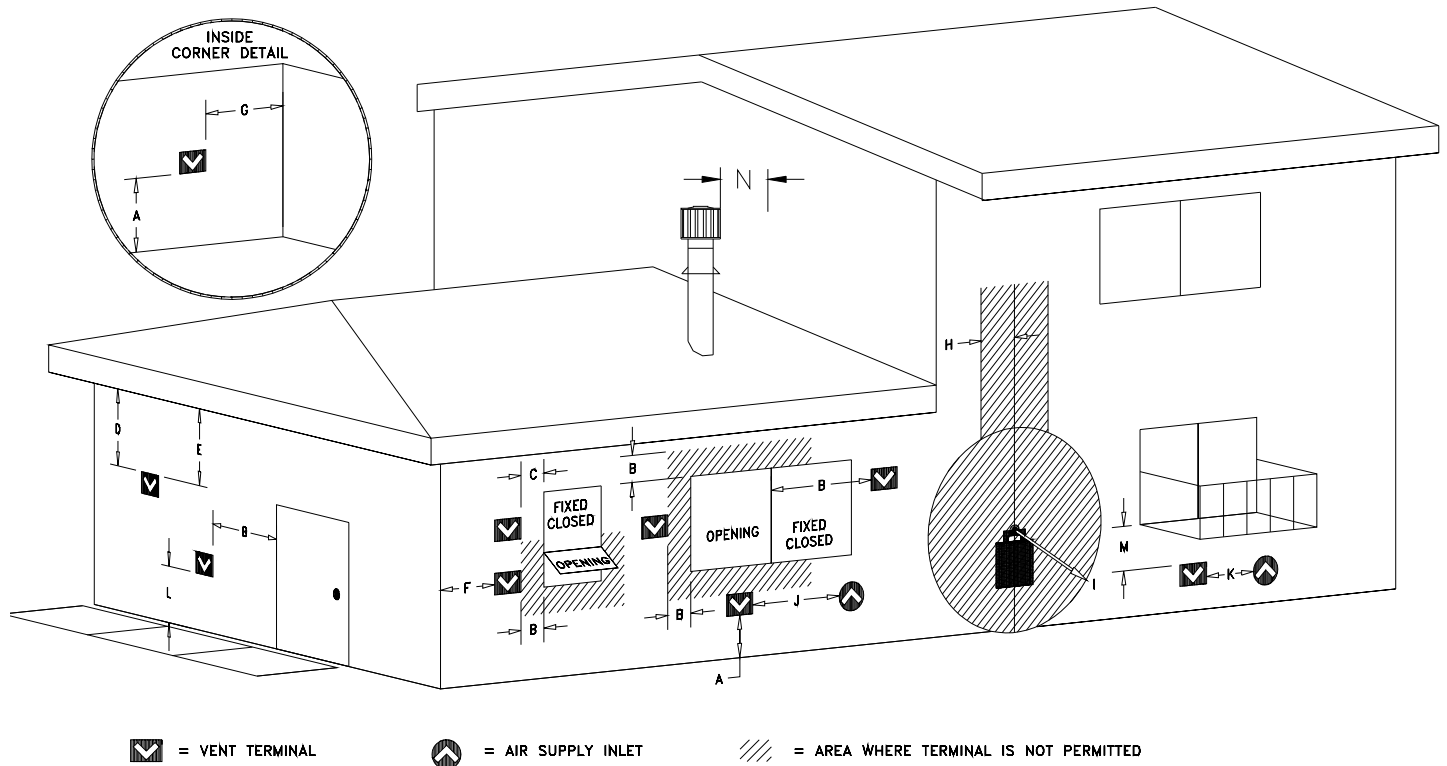

☑ = VENT TERMINAL

⬆ = AIR SUPPLY INLET

/// = AREA WHERE TERMINAL IS NOT PERMITTED

## ALL MEASUREMENTS FROM CENTERLINE OF VENT CAP

∨ - Vent Terminal

⬆ - Air Supply Inlet

≡ - Area where terminal is not permitted

- A = Clearance above grade, veranda, porch, deck, or balcony (\*12 inches (30 cm) minimum). Vinyl surfaces require 24" min.
- B = Clearance to window or door that may be opened (\*12 inches (30 cm) minimum).
- C = \*Clearance to permanently closed window (minimum 12 inches (30 cm) recommended to prevent condensation on window)
- D = \*Vertical clearance to ventilated soffit located above the terminal from the center-line of the terminal 24" (60 cm) min.
- E = \*Clearance to unventilated soffit 24" min (60 cm) min.
- F = Clearance to outside corner - 7 inches (18 cm).
- G = Clearance to inside corner - 12 inches (30 cm). Vinyl surfaces require 24" min (60 cm).

- H = \*Not to be installed above a meter/regulator assembly within 3 feet (90 cm) horizontally from the center-line of the regulator
- I = \*Clearance to service regulator vent outlet \*3 feet (92 cm) minimum.
- J = \*Clearance to non-mechanical air supply inlet to building or the combustion air inlet to any other appliance. 12 inches (30 cm) minimum.
- K = \*Clearance to a mechanical air supply inlet 6 feet (1.8 m) minimum
- L = † Clearance above paved side-walk or a paved driveway located on public property (\*7 feet (2.1 m) minimum)
- M = Clearance under veranda, porch, deck, or balcony (\*12 inches (30 cm) minimum ‡)
- N = Minimum 24" horizontal clearance to any surface, such as an exterior surface, for vertical terminations.

† A vent shall not terminate directly above a sidewalk or paved driveway, which is located between two single-family dwellings and serves both dwellings.

‡ Only permitted if veranda, porch, deck, or balcony is fully open on a minimum of two sides beneath the floor.

\* As specified in CGA B1:19 Installation Codes (1991). **Note:** Local codes or regulations may require different clearances.

## FLUE VENTING COMPONENTS IDENTIFICATION

**DO NOT SEPARATE TELESCOPING SECTIONS.  
USE TELESCOPING SECTIONS AS COMPLETE ASSEMBLIES.**

**HIGH ALTITUDE INSTALLATION INFORMATION:** Prior to installing at altitudes higher than 7500, please contact the Mendota technical service department for specific venting requirements and venting restrictions.

ITEM	DESCRIPTION
1	6" or 7" PIPE (DuraVent 6"/Amerivent 7"), 9", 12"
2	12" VENT STACK
3	24" VENT STACK
4	36" VENT STACK
5	48" VENT STACK
6	90° GALVANIZED ELBOW
	45° GALVANIZED ELBOW
7	ADJUSTABLE WALL THIMBLE
8	ATTIC INSULATION SHIELD 12"
9	ROOF FLASHING (0/12 TO 6/12)
10	ROOF FLASHING (7/12 TO 12/12)
11	STORM COLLAR
12	VERTICAL VENT CAP
13	SUPPORT BAND
14	HORIZONTAL VENT CAP
15	FIRE STOP SPACER

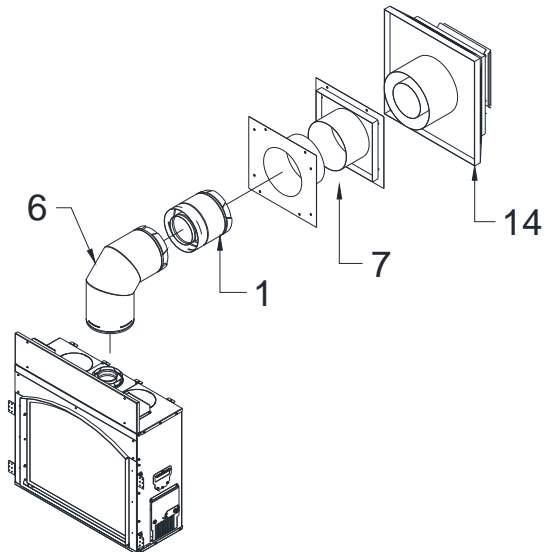

**Flue Venting Components**

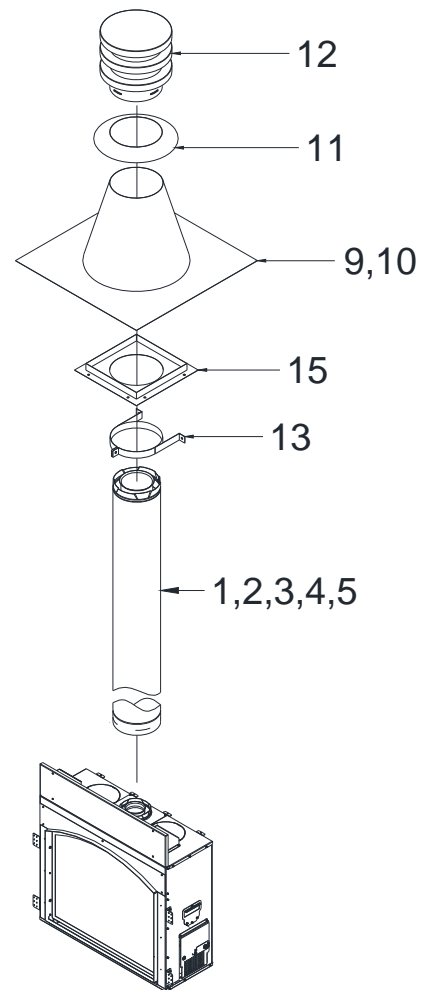

# FV34-ARCH MASTER FLUE VENTING REQUIREMENTS CHART

**NOTE:** THIS CHART IS APPLICABLE TO BOTH NATURAL GAS AND LPG INSTALLATIONS.

- 18 inches minimum vertical pipe run required to be connected directly to this fireplace's flue starter collar.
- Maximum Horizontal run allowed with the minimum 18" vertical run is 6".
- Maximum Vertical Run allowed is 40 feet.
- Maximum Vent System length allowed is 40 feet.
- 25 feet maximum horizontal run allowed with a minimum 5 to 15 feet starter section. If the starter vertical section is less than 5 feet, use the chart and reduce 3 feet for every 90° elbow installed after the first 90° elbow.
- 25 feet maximum horizontal run allowed only if the first vertical section connected directly to the top of this fireplace is 5 feet or longer. Three 90° elbows may be installed anywhere within the 25 feet horizontal run. For ALL horizontal terminations, only 3 90° elbows allowed.
- For ALL vertical terminations, four 90° elbows allowed. However, the 4<sup>th</sup> 90° elbow must point vertically and directly to the vent termination Cap.

V min	H max
18 in.	6"
24 in.	4'
36 in.	11'
48 in.	18'
60 in.	25'
5 ft. - 15 ft.	25'
15ft. - 40 ft.	Varies

MASTER VENT CHART

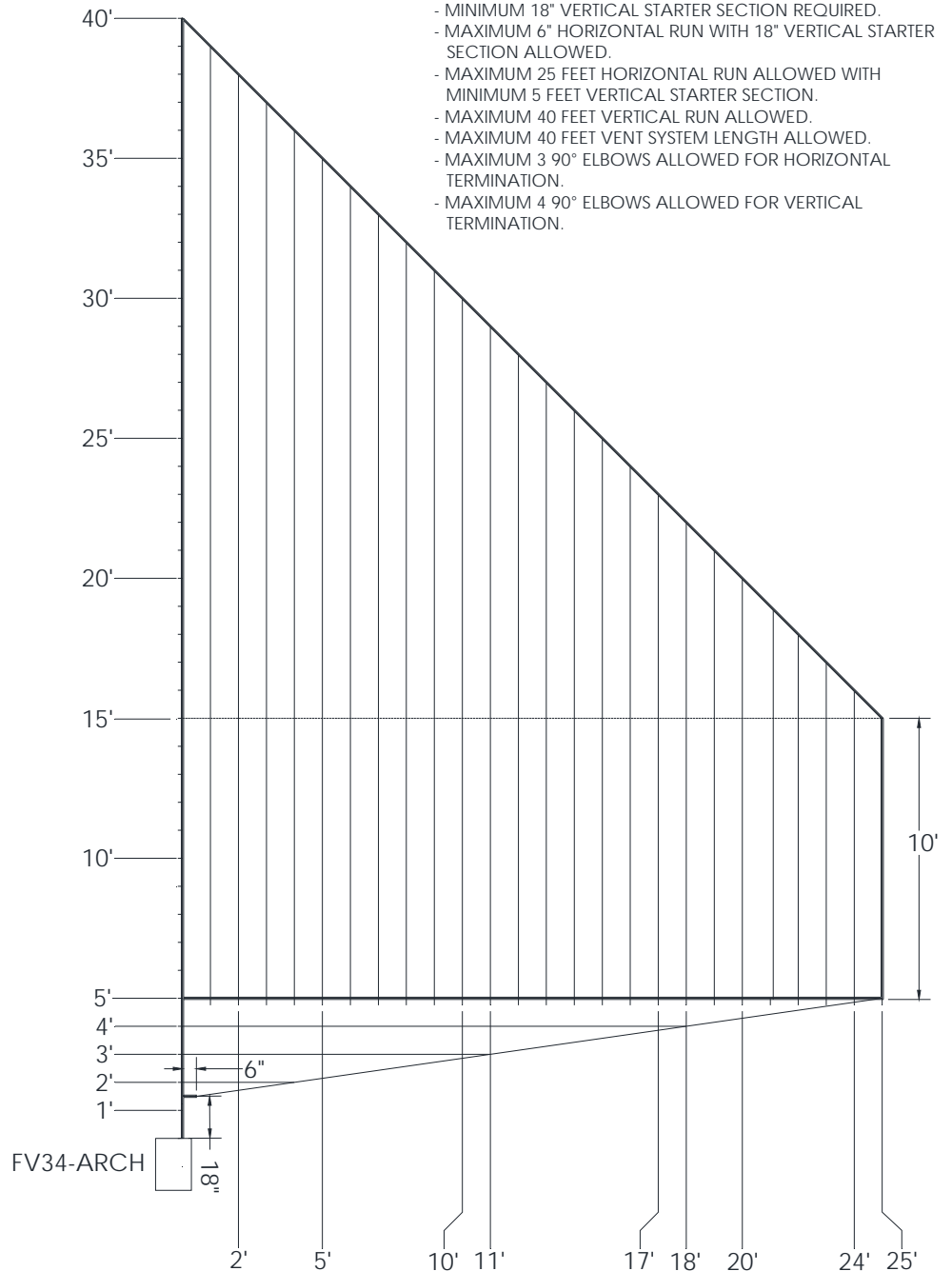

## **IMPORTANT VENTING CONFIGURATION NOTES**

See [MASTER FLUE VENTING REQUIREMENTS CHART].

**HIGH ALTITUDE INSTALLATION INFORMATION:** Prior to installing at altitudes higher than 7500, understand the gas Deration requirement and adjust burner gas orifices accordingly. If unable, please contact the Mendota technical service department for specific venting requirements and venting restrictions.

### **MAXIMUM HORIZONTAL RUN**

- A. Maximum Horizontal Run allowed is 25 feet if a vertical starter section that is between 5 feet to 15 feet is connected directly to this fireplace's flue starter collar and no more than three (3) 90 degree elbows are used.
- B. Maximum Horizontal Run allowed is 6" if an 18" starter vertical section then a 90-degree elbow is connected directly to this fireplace's flue starter collar.

### **MAXIMUM VENT SYSTEM LENGTH**

- A. Combined total length of all straight pipe sections in the vent system shall be less than 40 feet.
- B. Combined total length of all straight pipe sections in the vent system shall be less than 40 feet when using three (3) 90-degree elbows or equivalent and terminating the vent system horizontally.
- C. Combined total length of all straight pipe sections in the vent system shall be less than 40 feet when using four (4) 90-degree elbows or equivalent and terminating vertically.

### **USING 90° ELBOWS**

The FV34-ARCH Fireplace by MENDOTA allows maximum flexibility in the use of 90° elbows in the vent system. The length of the first straight vertical section directly connected to the fireplace's starter collar determines the maximum horizontal run and the number of 90° elbows allowed for this fireplace.

For vent systems that provide a starting vertical section that is 5 to 15 feet, you may connect up to 25 feet of horizontal pipe and up to three (3) 90° elbows.

### **USING 90° ELBOWS WHEN THE INITIAL STARTER VERTICAL SECTION IS LESS THAN 5 FEET OR OVER 15 FEET**

For vent systems that provide a starting vertical section less than 5 feet, the following rules apply:

- a. You must use the Master Flue Venting Requirements Chart.
- b. A single 90° vertical-to-horizontal elbow is already calculated into the allowable maximum 25' horizontal run. The Venting Requirements Chart assumes that for all horizontal runs calculated, one 90° elbow is used within the venting system. **Each additional 90° elbow reduces the maximum horizontal distance allowed by 3'.**
- c. If you plan to use more than one 90° elbow within the vent system, first use the Venting Requirements Chart and calculate the maximum horizontal run you are allowed based on the first vertical section connected directly to the fireplace. From this maximum horizontal run calculated, subtract 3 feet for each additional 90° elbow you will use.

**Example 1:** Assume you are using a 3 feet long starter vertical section. This should allow, per the Master Venting Chart, 11 feet of horizontal run. If you want to use three 90° elbows, subtract 6 feet for two elbows from the 11 feet maximum allowed [3 feet for each elbow after the first elbow]. This yields 5 feet as the maximum horizontal run that you are allowed to install using the 3 foot vertical starter section.

**CAUTION:** If a vertical-to-horizontal discharge elbow or a horizontal-to-horizontal discharge elbow is enclosed within a wall, floor or ceiling, a top air space clearance of 2" must be maintained above the entire body of the elbow.

### **USING 45-DEGREE ELBOWS**

Two 45-degree elbows may be used in place of one 90° elbow. On 45° runs, one foot of diagonal pipe is equal to 8-1/2 inches horizontal run and 8-1/2 inches vertical run. Two 45-degree elbows may be connected directly to the vent starter adapter on this fireplace to create an offset to provide the required clearances to combustible framing or sheathing materials.

Two 45-degree elbows may be connected directly to the top of this fireplace to create a horizontal offset. 25 feet maximum horizontal run allowed with this offset configuration only if the first vertical section connected directly to the last 45-degree elbow is more than 5 feet long. For maximum allowable horizontal distances with the 45-degree offsets, see the Master Venting Configuration Chart.

**Note:** Each horizontally positioned 45° elbow reduces the maximum horizontal distance by 1½'.

**SUPPORT:** Horizontal runs of pipe will require one vent support for every 3 ft. of pipe.

# APPROVED VENT SYSTEMS

## QUICK REFERENCE CHART

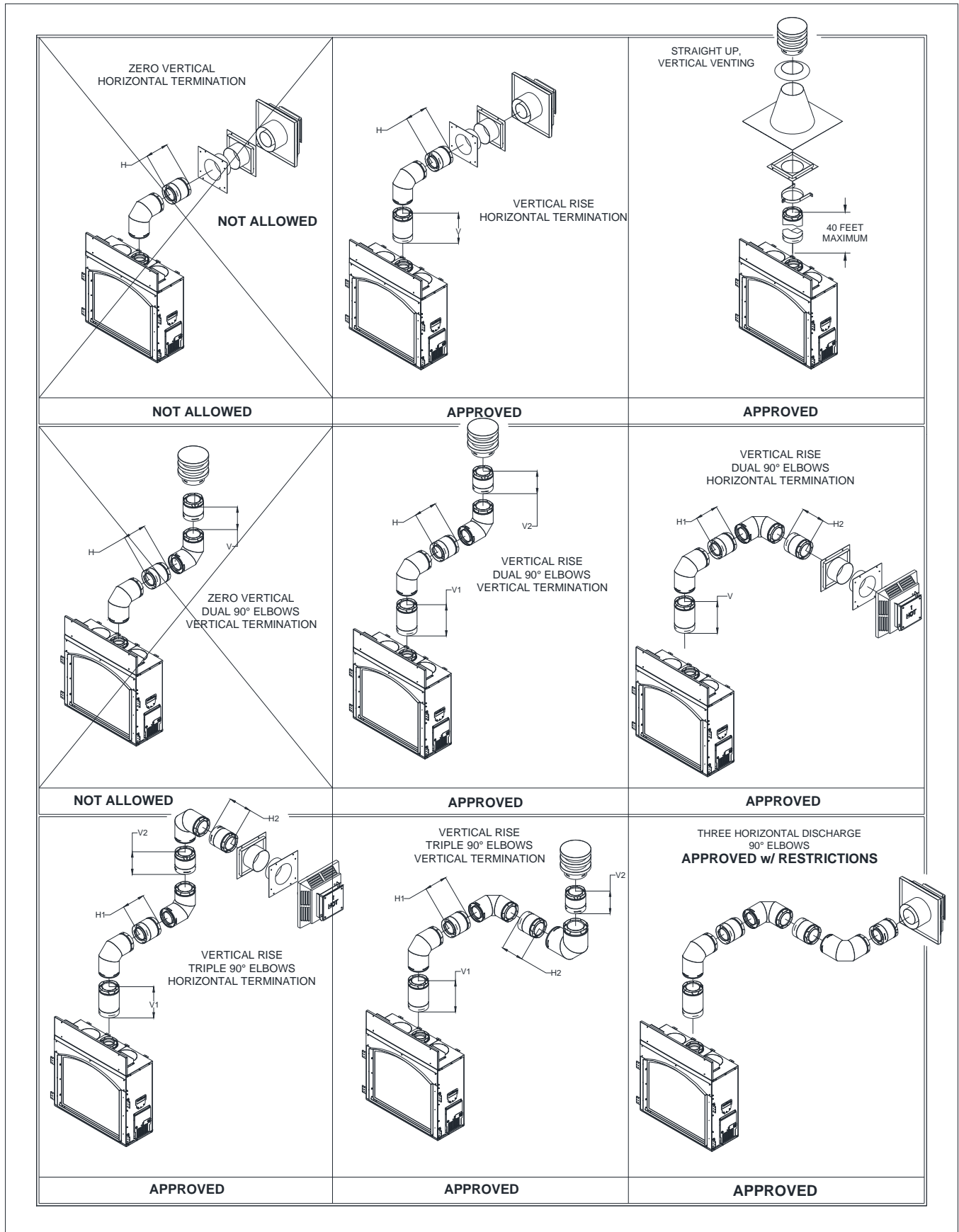



## **MINIMUM RISE (18") WITH HORIZONTAL TERMINATION**

**The FV34-ARCH Fireplace must be installed by a qualified Mendota approved serviceperson.**

A Maximum Horizontal Run of 6 inches is allowed if an 18" vertical starter section and one 90-degree elbow is connected directly to this fireplace's flue starter collar. The horizontal centerline of the 90° elbow will be 53-7/8" inches up from the floor level of this Fireplace.

See, MASTER FLUE VENTING REQUIREMENTS CHART and Figures, below.

Use "fixed" pipe sections in place of adjustable pipe sections wherever possible. 1000° sealant must be used on ALL inner pipe joints that do not have factory installed gasket material.

Always maintain 1" clearance from vent pipe sides and bottom to combustibles, 2" clearance on top of pipe on horizontal runs and on top of horizontal discharge elbows. Do not fill air spaces with insulation or other material.

**WARNING:** Verify your venting matches these dimensions before cutting a hole in the wall. Exact measurement can vary depending on the manufacture of the venting.

1. Position fireplace in desired location. See guidelines on proper vent cap placement on the exterior of home. Check to determine if wall studs are in the way when venting system is attached. If this is the case, you may want to adjust the fireplace location or modify the exterior wall framing to allow the vent system to penetrate the wall.
2. Measure from the floor level of the fireplace up 53-7/8" inches and mark wall directly at the center of where the vent pipe will penetrate the exterior wall.
3. Cut and frame a 9" wide x 10" high opening in the wall. The hole must be positioned so the vent system will have a ¼" rise per foot of run AND be perpendicular to the wall. The height of the opening must be located to meet all local and national building codes. Do not allow the termination to be easily blocked or obstructed. If wall being penetrated is non-combustible material, i.e. masonry block, brick, etc., an 8-inch diameter hole is acceptable.
4. Attach the 18" straight section to the fireplace starter adapter. Attach a 90-degree elbow to the top of the 18" vertical starter section and rotate and lock in position. Attach a horizontal section to the 90-degree elbow. Be sure all vent component connections are in their fully twist-locked position and are leak-proof. Be sure 1000° sealant is used on the inner pipe joints of all pipe sections manufactured by Simpson DuraVent. The length of the horizontal piece that fits through the wall will be determined by the location of the fireplace relative to the wall. For a normal installation where this fireplace is installed directly against an exterior wall constructed using 2x4 lumber or 2x6 lumber, only a 6" horizontal section is required. There MUST be a minimum of 1" air space clearance to combustibles from all vent components (2" above horizontal runs and horizontal discharge elbows).
5. **A wall thimble must always be used when penetrating combustible wall materials.**
6. From the exterior of the home, slide the horizontal vent cap over the end of the horizontal pipe and tightly secure the cap to the wall with screws. Seal with a high quality caulking.

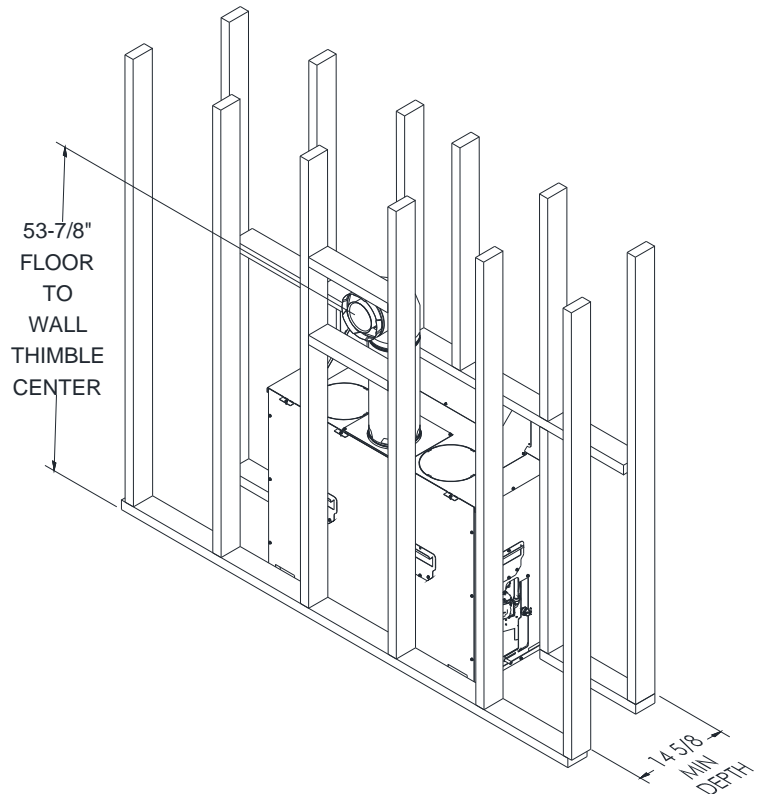

**NOTE:** Combustible wall thickness must be 4" to 8" maximum. Vent Cap shall not be recessed into wall or siding.

## **VERTICAL RISE HORIZONTAL TERMINATION**

The minimum vertical section required to be connected directly to the starter adapter on this fireplace is 5 feet when used with a maximum horizontal run of 25 ft. If the total length of the vertical sections connected directly to the starter adapter on this fireplace is between 5 feet and 15 feet, you are allowed a maximum 25 feet horizontal run. This fireplace provides a maximum flexibility in the use of 90° elbows when more than 5 feet of vertical starter section is connected to the starter collar. If 5 feet or more vertical section is connected to the starter collar, you may use three 90 degree elbows for Horizontal Terminations. For other venting configurations within these maximum limits, see Master Venting Chart.

Combined total length of all pipe sections in the vent system shall be less than 40 feet.

**NOTE:** The horizontal run of vent pipe must have a ¼" rise for every 1' of run toward the termination. Never allow the vent to run downward. This will cause high temperatures and the possibility of a fire.

### **This FV34-ARCH Fireplace must be installed by a qualified Mendota service person**

1. Position fireplace in desired location. See Figure 13 for guidelines on proper vent cap placement on exterior of home. Check to determine if wall studs are in the way when vent system is attached. If this is the case you may want to adjust the fireplace location.
2. Locate where vent pipe will pass through any ceilings and will penetrate the outside wall. Since vent pipe sections "overlap" we suggest pre-assembling and measuring the total vent pipe run so you can more accurately locate the point where the vent pipe will penetrate the outside wall (See Figure 13). Be sure all vent components are properly twist locked and leak-proof. Be sure 1000° sealant is used in the inner pipe joints of all pipe sections manufactured by Simpson DuraVent.
3. Cut and frame a 9" wide x 10" high opening in the outside wall openings and 9" x 9" opening in ceiling openings. The outside wall hole must be positioned so the vent system will have a ¼" rise per foot on horizontal runs AND be perpendicular to the wall. The height of the opening must be located to meet all building codes and not allow the termination to be easily blocked or obstructed. A ceiling fire stop spacer is required at any floor (ceiling) opening.
4. The horizontal pipe must end flush with the exterior wall of the home. Horizontal pipe will require a proper support every 3 ft. of vent pipe. **THERE MUST BE A MINIMUM OF 1" CLEARANCE TO COMBUSTIBLES FROM ALL VENT PIECES ON THE SIDES AND BOTTOM AND 2" ABOVE HORIZONTAL RUNS).**
5. **A wall thimble must always be used when penetrating combustible wall materials.**

**NOTE:** Combustible wall thickness must be 4" to 8" maximum.

**NOTE:** DO NOT SEPARATE TELESCOPING SECTIONS.  
THEY MUST BE USED AS COMPLETE ASSEMBLIES.

6. From the exterior of the home, slide the horizontal vent cap over the end of the horizontal pipe and tightly secure the vent cap to the wall with screws. Seal with high quality caulking around the outer perimeter of the Vent Cap.

**NOTE:** Venting terminal (Vent Cap) should not be recessed into wall or siding.

<b>V MIN</b>	<b>H MAX</b>
18"	6"
24"	4'
3'	11'
4'	18'
5'- 15'	25'
> 15'	= 40 - V
For V greater than 15', see Master Venting Chart	

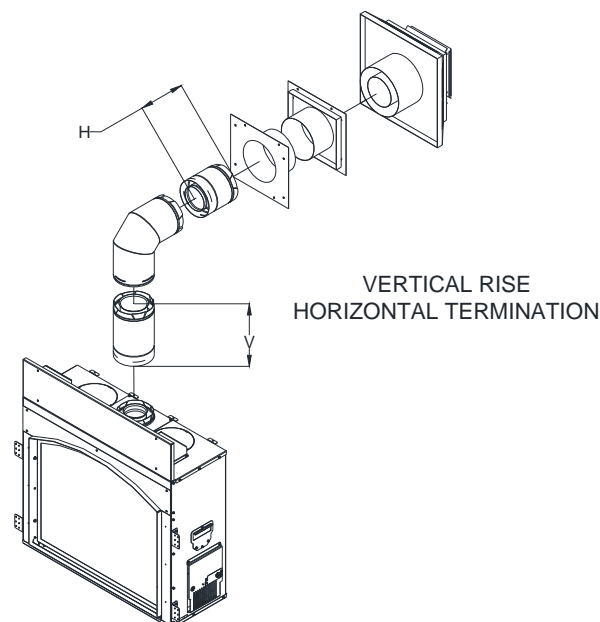

VERTICAL RISE  
 DUAL 90 DEG ELBOWS  
 HORIZONTAL TERMINATION

V(2' MIN)	H1 + H2 MAX
2'	1'
3'	8'
4'	15'
5'- 15'	25'

For V greater than 15', see Master Venting Chart

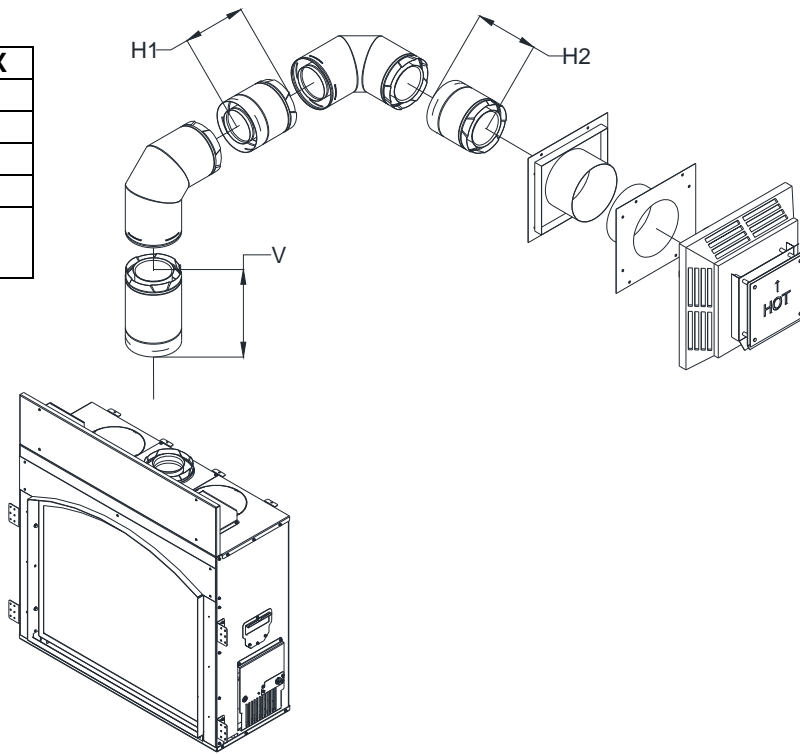

VERTICAL RISE  
 TRIPLE 90 DEG ELBOWS  
 HORIZONTAL TERMINATION  
 (Use the Master Venting Chart to calculate allowable lengths.)

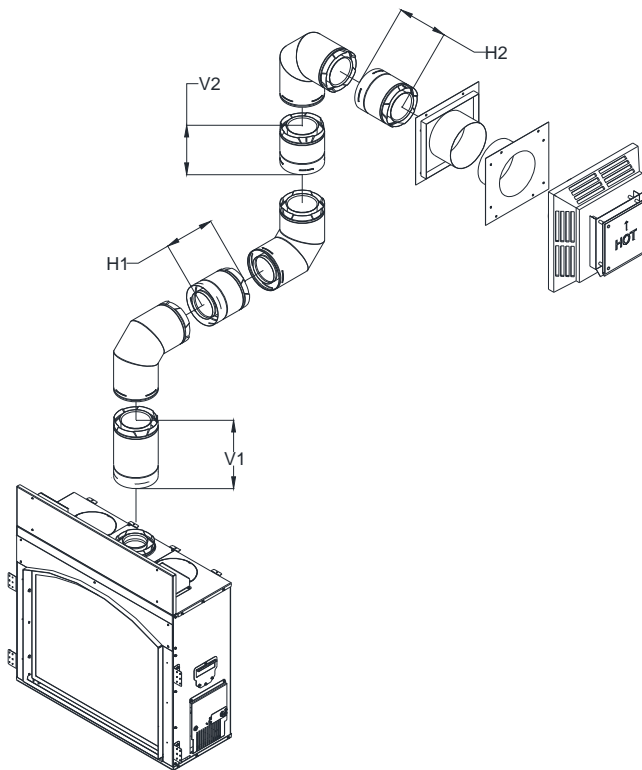

## **VERTICAL THROUGH-THE ROOF VENTING**

The maximum vertical run of vent pipe is 40 ft. from the top of the fireplace. The fireplace will support a run of a maximum of 40 ft. Maintain 1" air space clearances on all sides of vents (2" above horizontal runs).

If an offset is required directly on top of the fireplace, two 45° elbows may be connected directly to the top of this fireplace to create a horizontal offset then to run upwards vertically. Doing so will continue to allow the use of the 40 ft. maximum vertical run.

**The FV34-ARCH Fireplace must be installed by a qualified Mendota approved serviceperson.**

1. Place the fireplace in its desired location. Drop a plum bob from the ceiling to the position of the fireplace flue exit. Mark the location where the vent will penetrate the ceiling. Drill a small hole at this point. Next, drop a plum bob from the roof to the hole previously drilled in the ceiling. Mark and drill the spot where the vent will penetrate the roof. Determine if ceiling joists, roof rafters or other framing will obstruct the venting system. You may wish to relocate the fireplace or to offset, to avoid cutting load bearing members.
2. Cut and frame a 9" x 9" opening in the ceiling centered on the hole drilled in Step No. 1.
3. To determine the length of the vent pipe required, measure the distance from the fireplace flue outlet to the ceiling, the ceiling thickness and the vertical rise in the attic or second story and allow sufficient vent height above roofline. For two story installations, fire stops are required at each floor level. If an offset is needed in the attic, additional pipe and elbows will be required.
4. Assemble the desired lengths of vent pipe and elbows to reach from the fireplace flue outlet. Ensure that all vent pipe and elbow connections are in their fully twist-lock position and that inner pipe joints (DuraVent only) are sealed and are leak-proof. Maintain 1" airspace clearances to combustibles (2" above horizontal runs). Cut a 9" x 10" opening in the roof, centered in the small drilled hole placed in the roof in No. 1. The opening should be a sufficient size to meet all clearance requirements. Continue to assemble lengths of pipe and elbows necessary to reach up through the roofline. Galvanized pipe and elbows may be utilized in the attic, as well as above the roofline. The galvanized finish is desirable above the roofline due to its higher corrosive resistance.
5. If an offset is necessary, it is important to support the vent pipe every 3 ft. to avoid excessive stress on the elbows and possible separation. Wall straps are available for this purpose.
6. Slip the flashing over the pipe sections protruding through the roof. Secure the base of the flashing to the roof with roofing nails and seal flashing to roof. Ensure the roofing material overlaps the top edge of the flashing. Verify you have at least the minimum clearance to combustibles at the roofline.
7. Continue to add pipe sections until the pipe and the vent cap meet the minimum building code requirements.
8. For multi-story vertical installation, a ceiling fire stop is required at the second floor and any subsequent floors. The opening should be framed to 9" x 9" inside dimensions.
9. Any occupied areas above the first floor, including closets and storage spaces, which the vertical vent passes through, must be enclosed. The enclosure may be framed and sheet rocked with standard construction materials, however, be sure to maintain minimum allowable clearances between the outside of the vent pipe and the combustible surfaces of the enclosure.
10. Height "H" from roof surface to the top of vent cap can be determined as follows:
11. Complete installation with storm collar and vent cap.

ROOF PITCH	"H" DIMENSION	
	FEET	METERS
FLAT to 6/12	2	.6
7/12 to 9/12	2	.6
10/12 to 12/12	4	1.2
13/12 to 16/12	6	1.8
17/12 to 21/12	8	2.4

STRAIGHT UP,  
VERTICAL VENTING

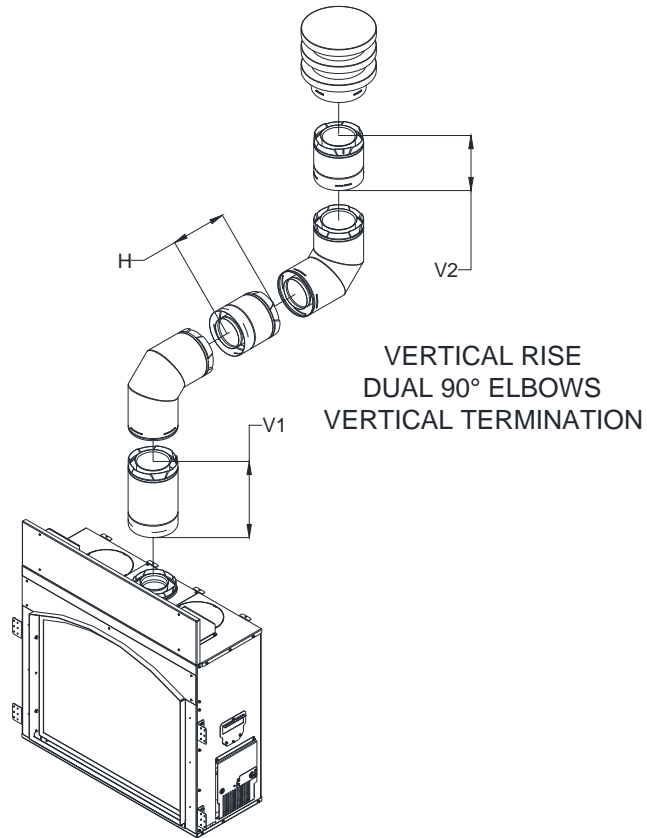
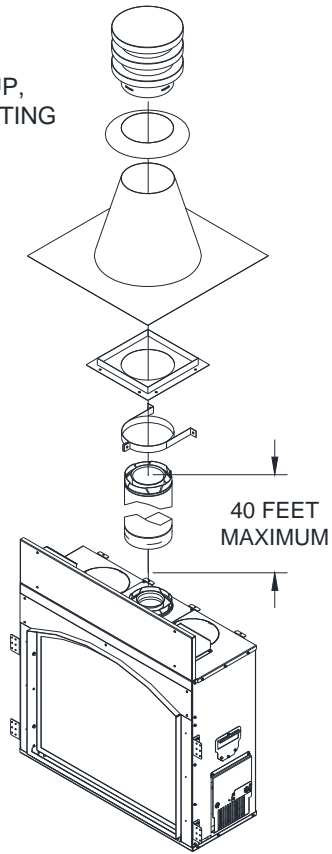

## VERTICAL THROUGH-THE-ROOF VENTING USING FOUR 90° ELBOWS

In extreme situations, Four 90° elbows may be required to reach a proper exit point for the vent system. Mendota has spent considerable time and effort in the design of this fireplace and its venting system. Through this effort, Mendota has been able to certify the use of Four 90° elbows when terminating vertically.

### **The use of Four 90° elbows must meet some minimum prerequisites.**

Prerequisite #1: The vent system must terminate vertically using a vertical vent cap.

Prerequisite #2: There must be a minimum 3 feet of vertical starter section connected directly to the top of this fireplace.

Prerequisite #3: For vertical starter sections less than 5 feet tall, you must reduce 6 feet off the maximum horizontal run allowed per the Master Vent Chart.

FOUR 90° ELBOWS, VERTICAL TERMINATION		
V1(3' MIN.)	H1+H2+H3 MAX	V2 MAX
3'	5'	= 34 - (V1 + H1 + H2 + H3)
4'	12'	= 34 - (V1 + H1 + H2 + H3)
5' to 15'	25'	= 40 - (V1 + H1 + H2 + H3)
> 15'	= 40 - V1	= 40 - (V1 + H1 + H2 + H3)

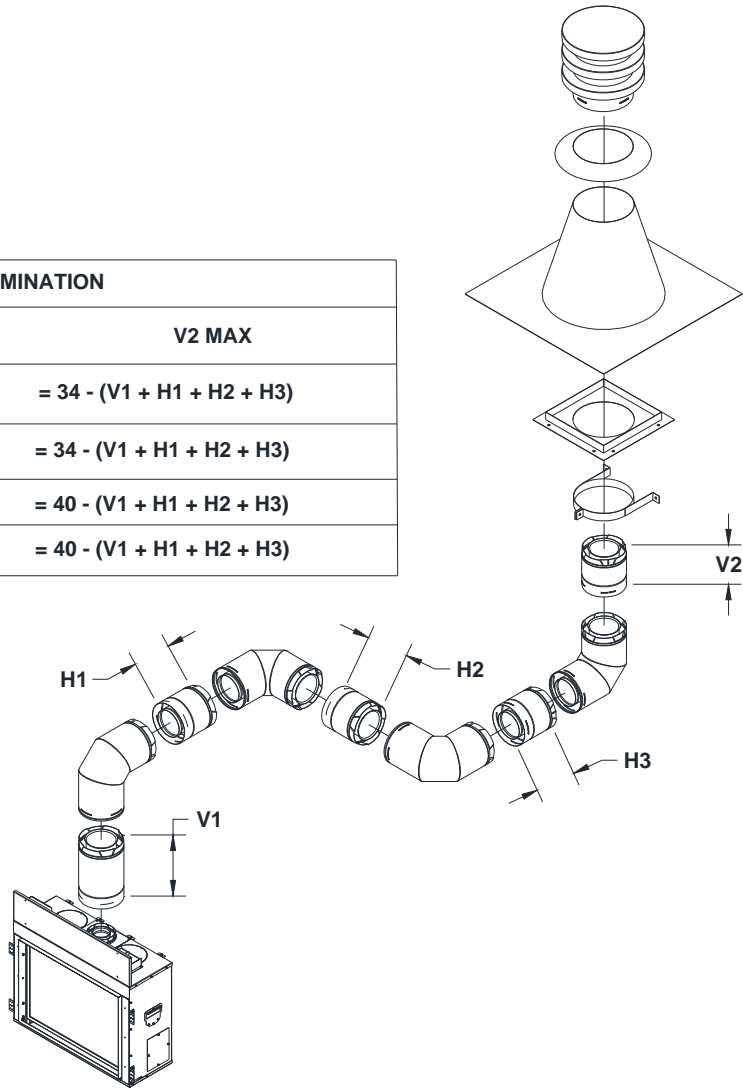

## FV34-ARCH DOOR OPERATION

### TO REMOVE DOOR

1. Use the glass latch tool to disconnect the spring latches from the glass frame. Insert tool into hole in latch, pull towards you and Rotate 90 degrees to disengage top latches. Remove tool. **There are two spring latches on top of this gas fireplace.**
2. With both hands, rotate top edge of glass frame away from unit 8 inches.
3. Lift glass frame up 1 inch, at an angle, and move away from unit.
4. Door is now free from unit.

### TO REPLACE DOOR

1. Line up the three bottom tabs in glass frame bottom with slots in glass clips on firebox bottom. Insert tabs into slots and center tabs in slots, left to right.
2. Center Glass Frame over Firebox; left to right.
3. After door has been placed into slots, rotate door towards firebox until gasket seal is touching the firebox frame.
4. Use the tool provided to connect the spring latches to the glass frame. Insert tool into hole in spring latch, pull latch towards you, rotate latch so the hook is facing downward then release latch to hook to door frame.
5. Door is now connected and sealed to unit.

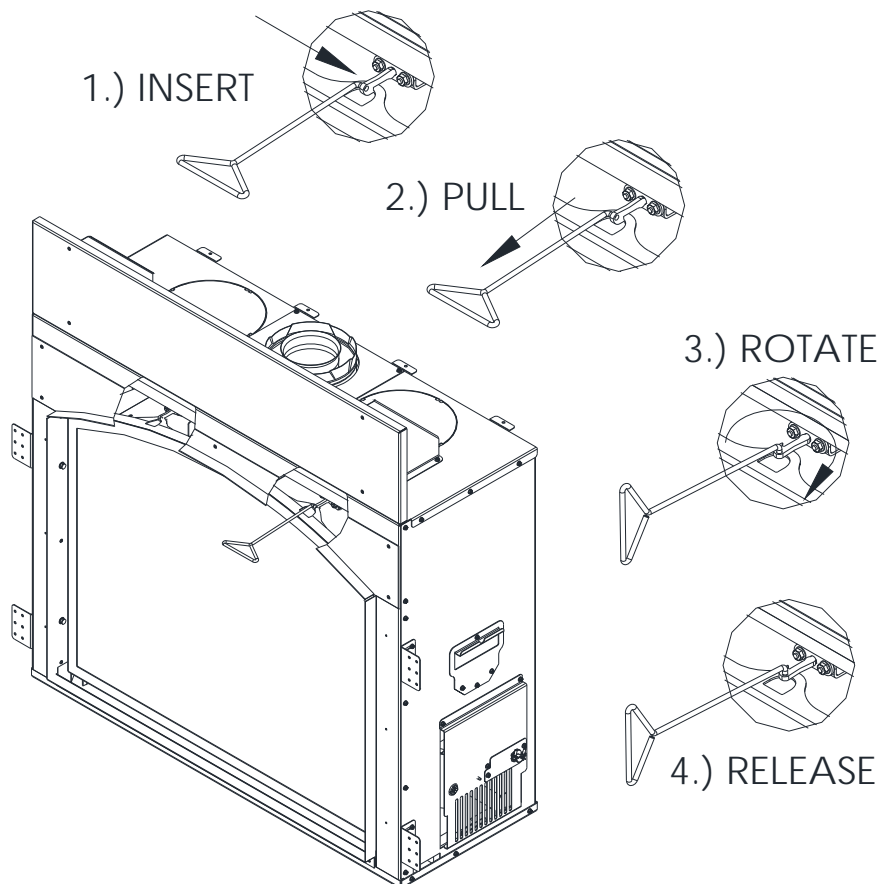

## **BLOWER SYSTEM INFORMATION**

**WARNING: Label all wires prior to disconnection when servicing controls. Wiring errors can cause improper and dangerous operation. Verify proper operation after servicing.**

This appliance is equipped with an internal three-wire (grounding) cable for protection against shock hazard and should be hard-wired directly to a properly grounded three-wire home power supply cable within an approved junction box or within this appliance body. Do not cut or remove the grounding wire.

A powerful single blower is provided as standard equipment with this FV34-ARCH fireplace. The blower has an air output rating of 105 CFM (in free air). This fireplace is designed to operate with the blowers turned OFF or ON. Turning the blower on aids in distributing and circulating heat to the room this fireplace is installed in.

### **BLOWER OPERATION**

The remote control system supplied with this appliance can turn the blowers ON or OFF and regulate the speed of the blowers in six (6) steps.

**NOTE:** In the Normal Thermostat Mode and the SMART Mode, there will be a time delay in blower operation during "heat-up" (5 minutes) and extended blower operation during "cool-down" of unit (12-1/2 minutes).

## **FV-34 BLOWER WIRING DIAGRAM**

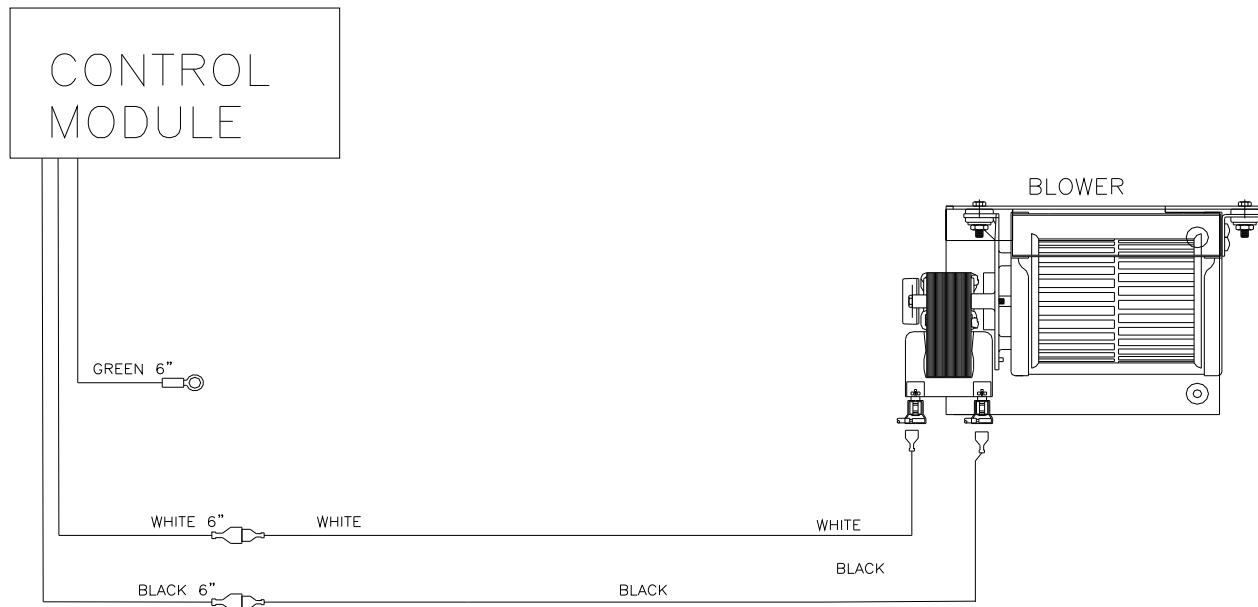



## INSTALLATION CHECK OFF LIST

- Co-axial vent rigid pipe, wall vent cap or roof vent cap must be installed by a Mendota approved person in accordance with instructions. All joints must be secured, "twist-locked" and leak-proof. 1000°F sealant must be used on the inner pipe joints of all DuraVent pipe sections.
- Horizontal or vertical vent cap must be installed "**right-side-up**" and tightly sealed to structure per instructions. Vent Caps must be Mendota approved.
- Proper exterior and interior clearances for vent systems and locations for wall vent cap/roof vent cap must be maintained.
- Carefully check for correct gas pressure, proper size gas lines and for gas leaks.
- 115 V electrical service and gas supply must be installed in accordance with instructions and local and national codes.

## LIGHTING CHECK OFF LIST

- All items on "Installation Check Off List" (see above) must be completed.
- Check for gas leaks and gas pressures prior to installing facing materials.
- Install fresh batteries in remote transmitter. Follow "Initializing the System for the first time" instructions to synchronize the remote control and the ignition module.
- Check air shutter opening - 0" to 1/8" Nat. gas or 1/4" to 1/2" LP gas.
- Carefully follow all Lighting and Log Installation Instructions.
- Make certain that burners light immediately and flame runs promptly around "curve" in rear burner and lights entire burner. DO NOT proceed with operation unless burner cycles "on/off" without delays.
- Make certain that the flame is "stable" and does not "lift" off burner. If flame lifts off burner, turn unit off and check that all vent pipes are "twist locked" and leak proof, the vent cap is "right side up" and that 1000° Sealant has been used on the inner pipe joints of all DuraVent pipe sections. DO NOT proceed with operation if flame is "lifting off" burner.  
**Note: Do not separate telescoping sections. They must be used as complete assemblies.**
- Make certain glass door is in proper closed position and "centered" in firebox opening.

## **LOG SET INSTALLATION**

Open the box and, very gently and carefully, pull out the three foam packages and lay on the floor.

Use a utility knife to cut tape strips that secure foam package tops to foam package bottoms. Lift off foam package top very slowly and carefully. If you find that the foam package is upside down, reverse it before attempting to separate the top and bottom foam trays.

It is of the utmost importance that you treat every package and every twig piece and assembly like you would an egg. Breakage is your responsibility and is not covered by a Warranty Policy.

The diagrams, below, show all the parts included with this log set.



PLACE **LOG #1 (REAR LOG)** ON REAR SHELF BEHIND REAR BURNER. CENTER LOG ON THE AIRBOX. PUSH LOG BACK SO IT TOUCHES REAR BRICK PANEL.



**LOG #2 (MID EMBER BED)** SITS BETWEEN REAR AND FRONT BURNER, FLAT DOWN ON THE SURFACE OF THE BURNER AIRBOX. ADJUST POSITION OF FRONT AND REAR BURNERS IF LOG #2 DOES NOT SIT BETWEEN REAR AND FRONT BURNER.

PLACE LOG #2 BETWEEN THE TWO BURNERS AND SLIDE TO THE RIGHT UNTIL THE CURVATURE IN THE FRONT BURNER CONTACTS THE CURVATURE ON THE RIGHT FRONT TIP OF LOG #2. PUSH LOG #2 DOWN TO INDENT THE BOTTOM WITH THE TWO BURNER MOUNTING SCREW HEADS. LOG #2 MUST NOT ROCK ON TOP OF THE SCREW HEADS. LOG #2 MUST BE STABLE.

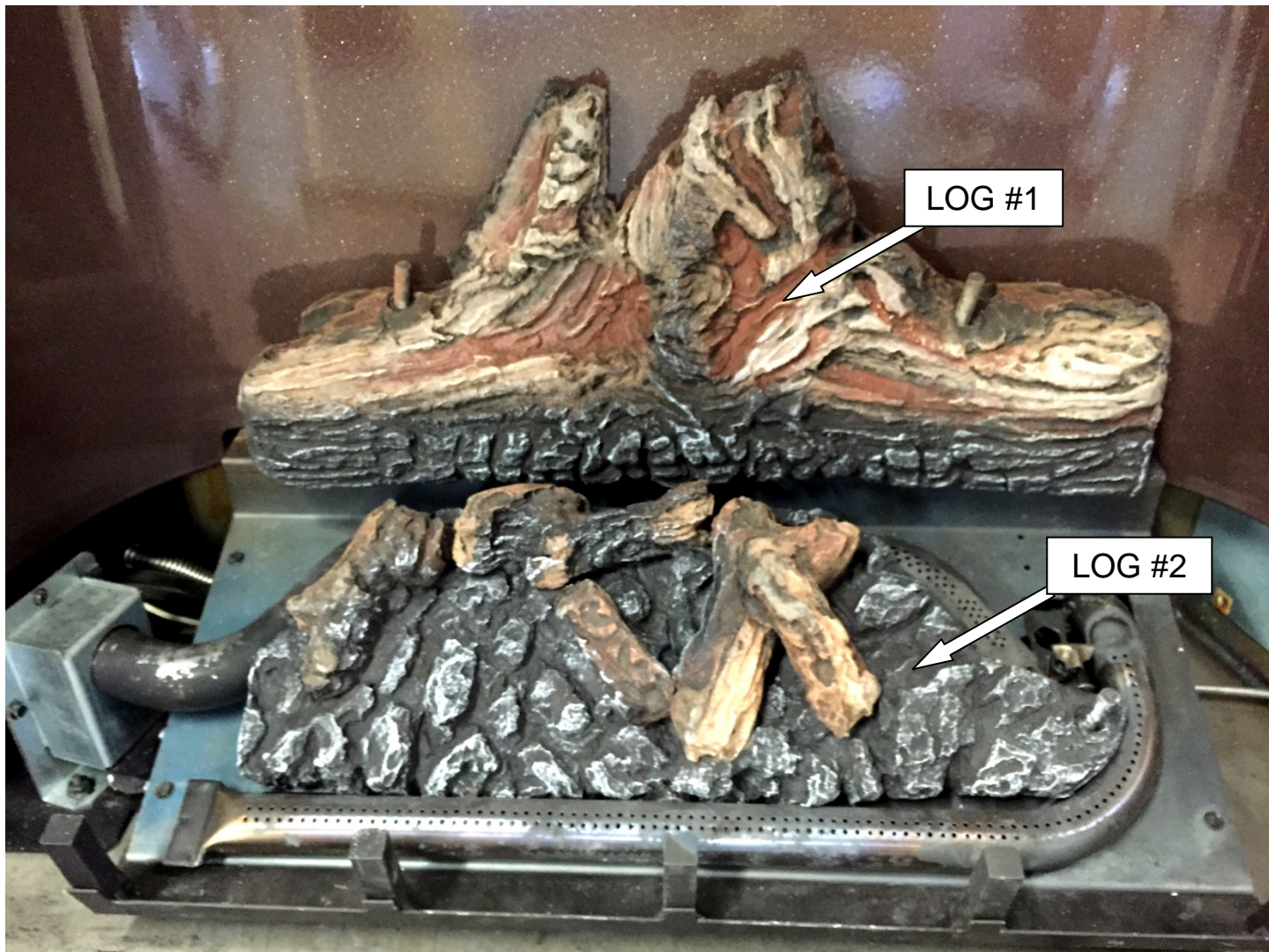

PLACE **LOG #3 (LEFT LOG)** ON TOP OF THE RECTANGLE AIR SHUTTER BOX ON THE LEFT SIDE. LOG #3 HAS A RECTANGULAR NOTCH ON ITS BOTTOM SIDE THAT ALLOWS THE LOG TO SIT SQUARELY ON THE BOX. ALSO, THERE IS A NOTCH THAT MATES WITH THE LEFT-MOST GRATE BAR. SET LOG #3 ON THE GRATE BAR AND THE RECTANGLE SHAPED AIR SHUTTER BOX TOP SURFACE.

LOG #3 MUST LEAVE CLEARANCE FOR THE REAR BURNER PORTS. SOME ROTATIONAL FLEXIBILITY IS ALLOWED FOR THE REAR END OF THIS LOG TO ROTATE TOWARDS LOG #2. HOWEVER, LOG #3 SHALL NEVER SIT ON TOP OF THE REAR BURNER PORTS. DOING SO WILL LEAD TO SOOT CREATION.

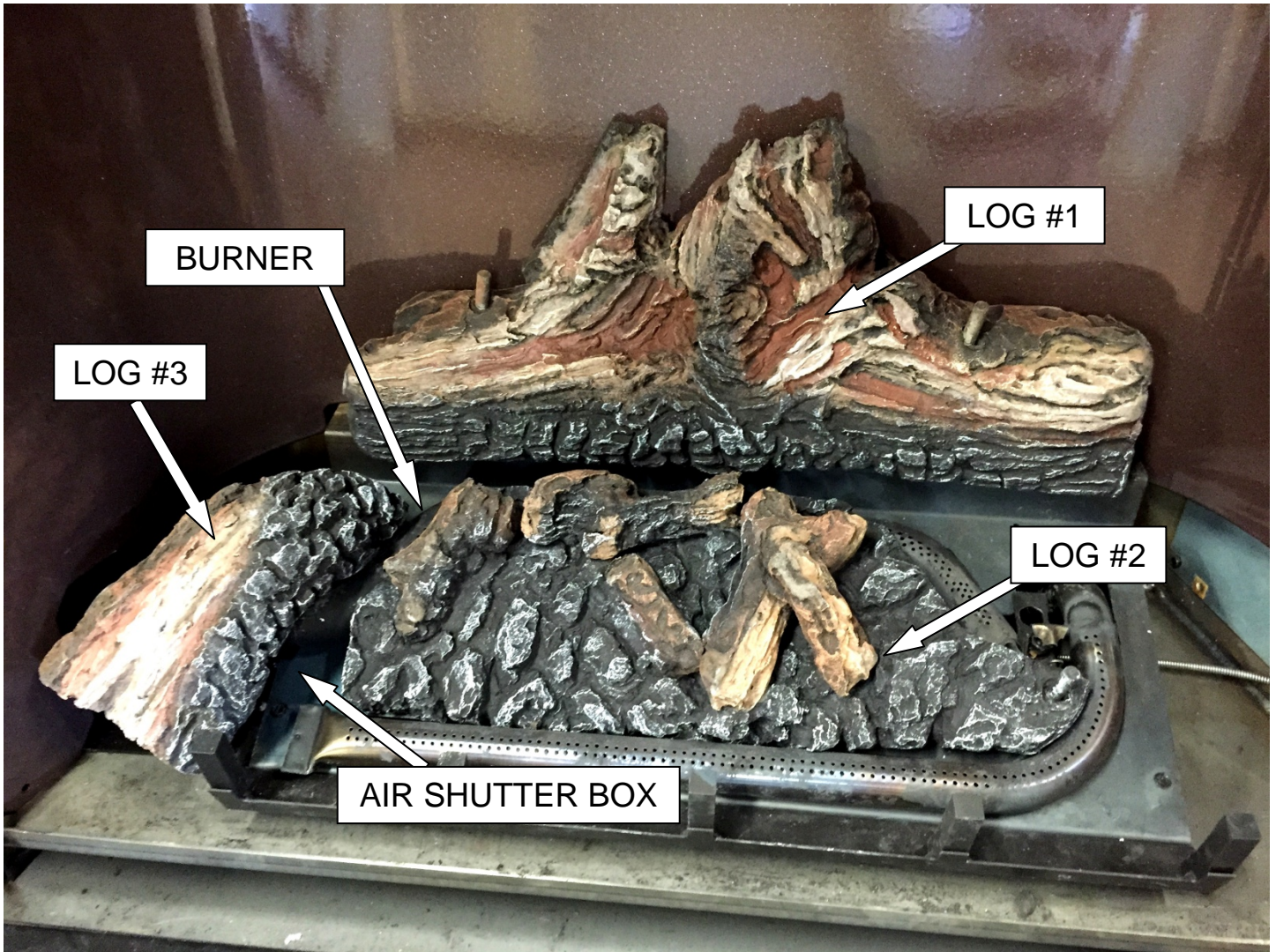

**LOG #4 (RIGHT LOG) HAS A HOLE FOR THE PIN ON LOG #2.**

INSERT PIN IN LOG #2 INTO HOLE IN LOG #4. SET RIGHT END OF LOG #4 ON TOP OF THE FIRST GRATE BAR ON THE FAR RIGHT SIDE.

SOME ROTATIONAL FLEXIBILITY IS ALLOWED TO LOG #4 AROUND THE PIN AND HOLE. HOWEVER, DO NOT ROTATE REAR END OF LOG OUTWARD. ROTATE INWARD ONLY IF DESIRED. ROTATING OUTWARD MAY PLACE LOG #4 ON TOP OF REAR BURNER PORTS AND MAY LEAD TO SOOTING.

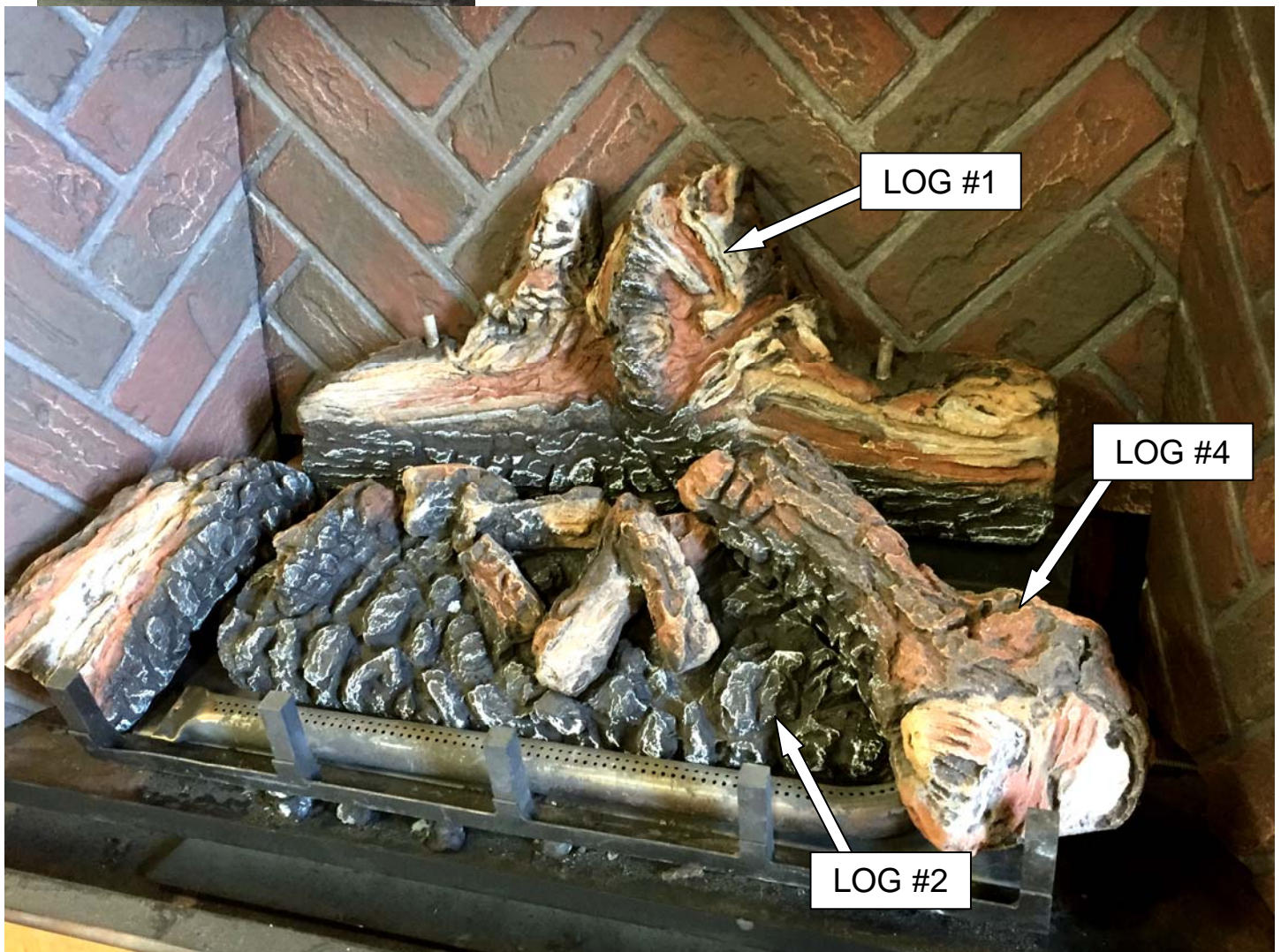
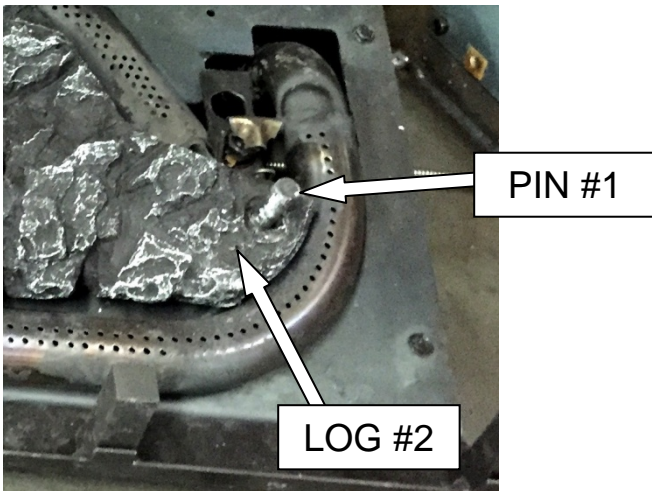

**LOG #5 (LEFT TOP LOG)** SITS ON THE LEFT SHOULDER OF LOG #1 AND ITS TWO BRANCHES SIT ON TOP OF LOG #2 AND LOG #3. LOG #5 HAS A HOLE THAT ALIGNS WITH THE LEFT SIDE PIN ON LOG #1. THE V-NOTCH BETWEEN THE TWO BRANCHES MUST SIT DIRECTLY ON TOP OF THE REAR BURNER'S LEFT SIDE PORTS AND MUST ALLOW THE FLAMES TO RISE INTO THE V-NOTCH IN THIS LOG. PUSH LOG #5 BACK SO ITS REAR END TOUCHES THE REAR BRICK PANEL.

PIN FOR LOG #5

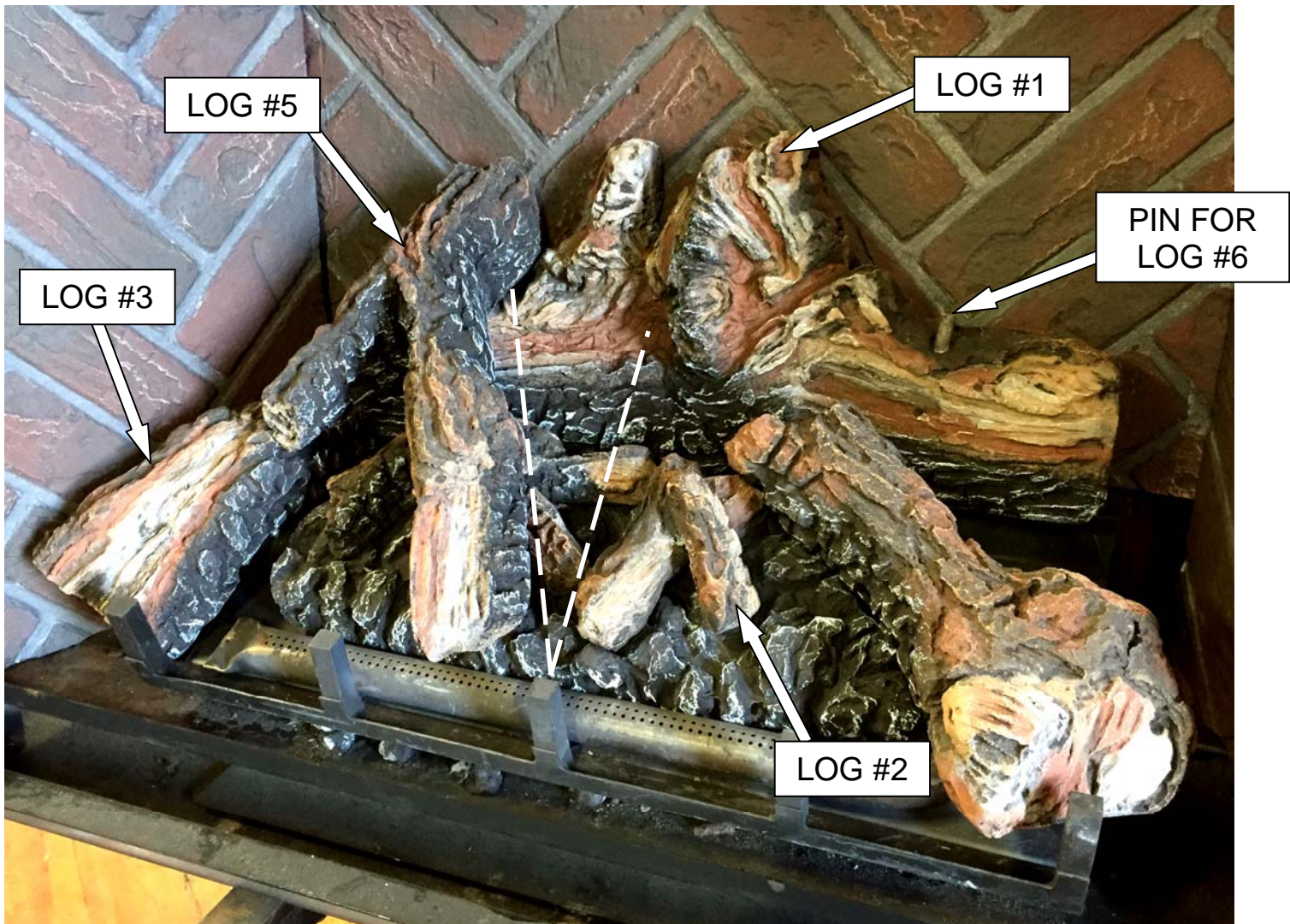

**LOG #6 (RIGHT TOP LOG)** SITS ON TOP OF LOG #1 USING THE PIN THAT IS ON THE RIGHT SIDE OF LOG #1. LOG #6 HAS A HOLE IN ITS BACK-SIDE TO MATE WITH THIS PIN.

PLACE LOG #6 ON TOP OF LOG #1'S PIN. THE OTHER END OF LOG #6 SITS ON TOP OF LOG #2 AS SHOWN, BELOW.

SOME ROTATIONAL FLEXIBILITY IS ALLOWED FOR LOG #6. THE POSITION OF LOG #4 WILL LIMIT THE ROTATION OF LOG #6.

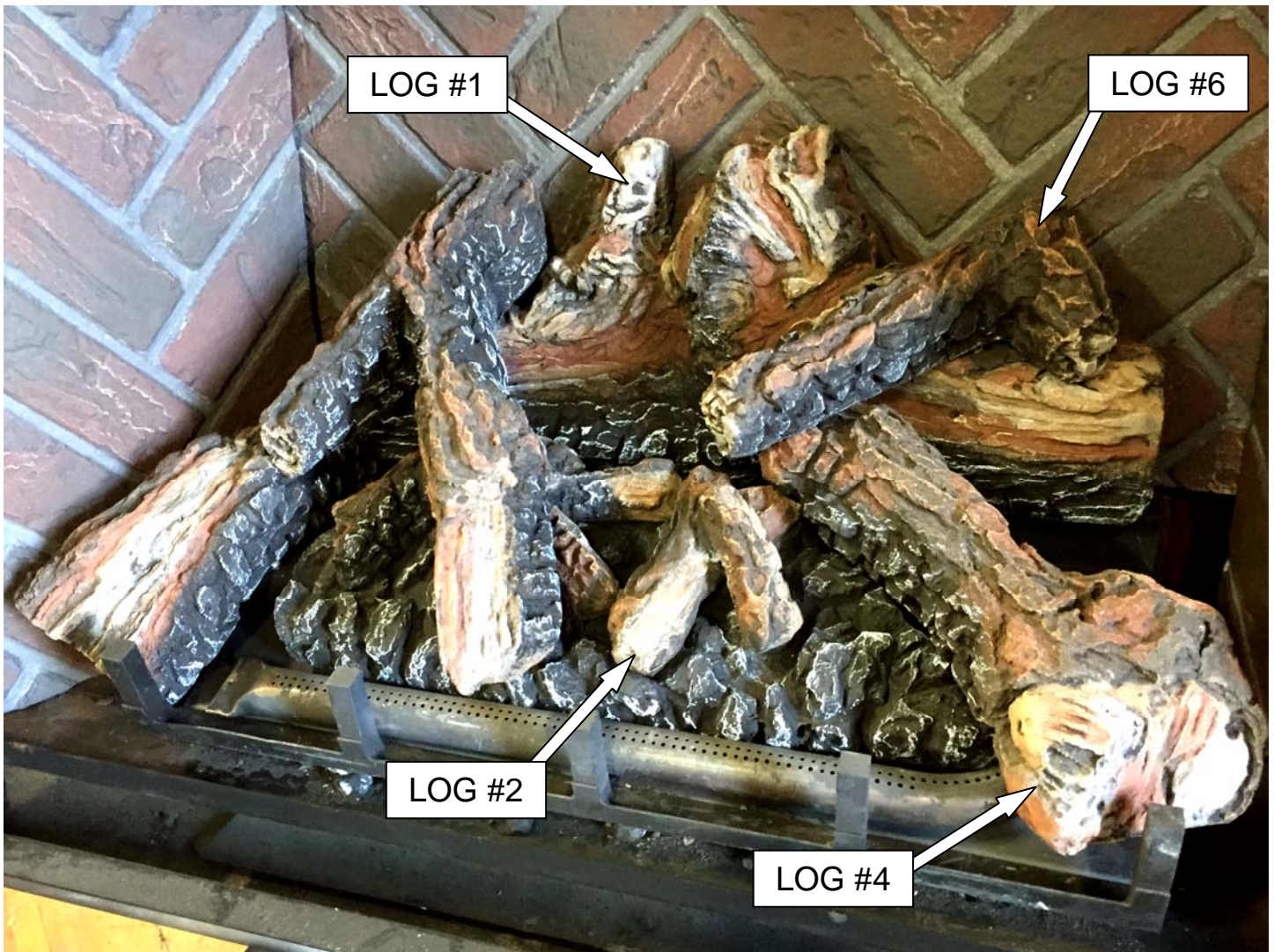



**LOG #7 (FAR RIGHT MID LOG)** RESTS ON TOP OF THE FRONT BURNER'S REAR VISIBLE EDGE AND ON TOP OF LOG #4. THIS LOG IS DESIGNED TO HIDE THE PILOT LIGHT. PLACE THIS LOG SO IT PROVIDES CLEARANCE TO ALL BURNER FLAMES AND PILOT FLAMES, YET POSITIONED TO HIDE THE PILOT FLAMES.



PLACE **LOG #8 ( LEFT FRONT TWIG )** IN THE POSTION SHOWN HERE. LOG #8 SITS ON TOP OF LOG #2 AND RESTS AGAINST THE GRATE BAR (2ND FROM LEFT). ATTEMPT TO POSITION LOG #8 AS SHOWN HERE FOR THE BEST GLOW EFFECT AND REALISTIC LOOK. DO NOT PINCH FRONT BURNER PORTS WITH LOG #8.

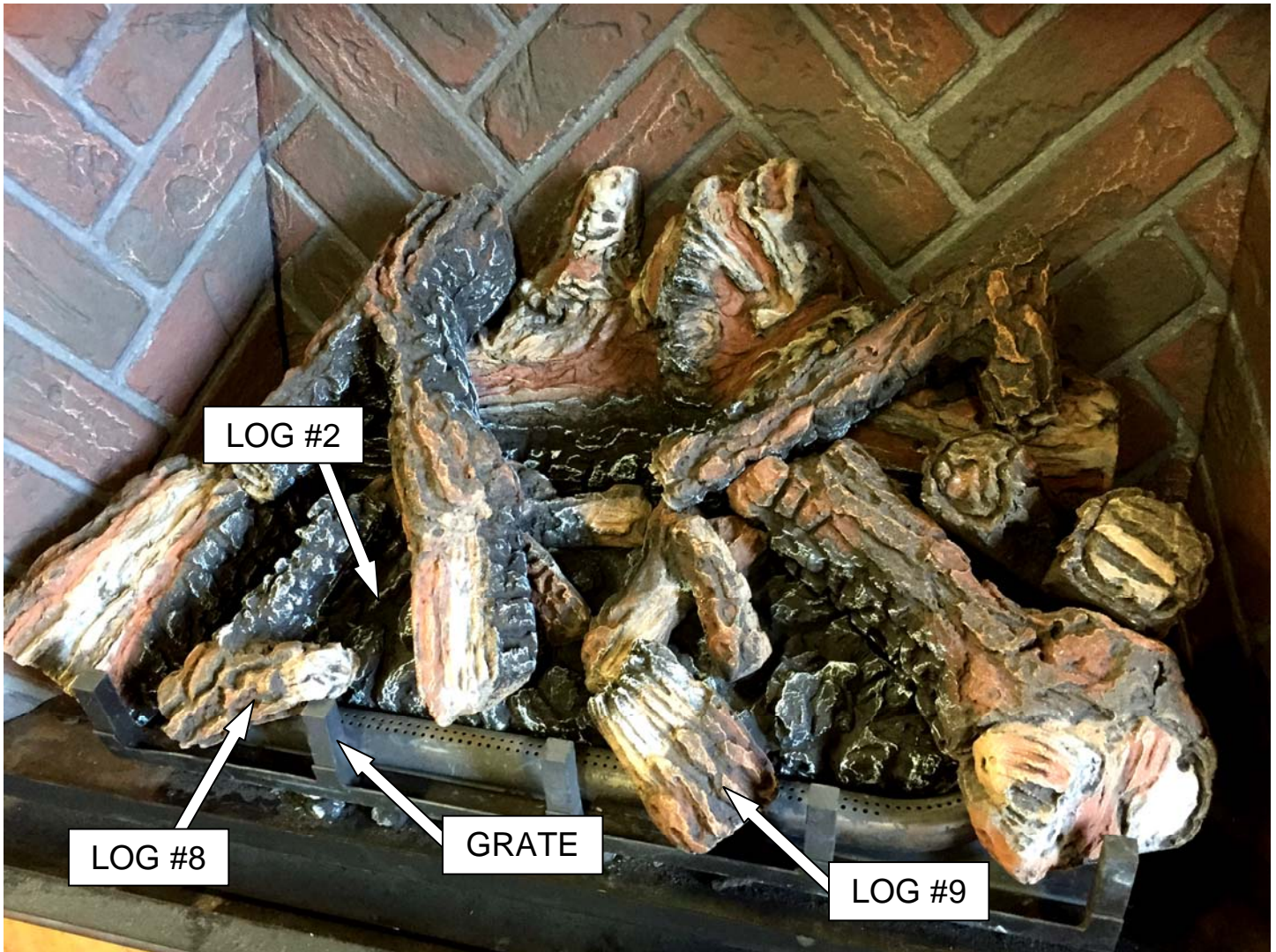

**LOG #9 (RIGHT FRONT CHUNK)** IS TO BE PLACED AT A SEVERE ANGLE AGAINST THE HORIZONTAL GRATE BAR AND FLOATING OVER THE FRONT BURNER PORTS. THE POSITION OF THIS LOG IS NOT CRITICAL. HOWEVER, DO NOT PLACE THIS LOG DIRECTLY ON TOP OF THE FRONT BURNER PORTS AND DO NOT PLACE THIS LOG ON TOP OF LOG #2.

PLACE LOG #10 (FAR RIGHT LOG) ON THE FIREBOX FLOOR NEXT TO LOG #4

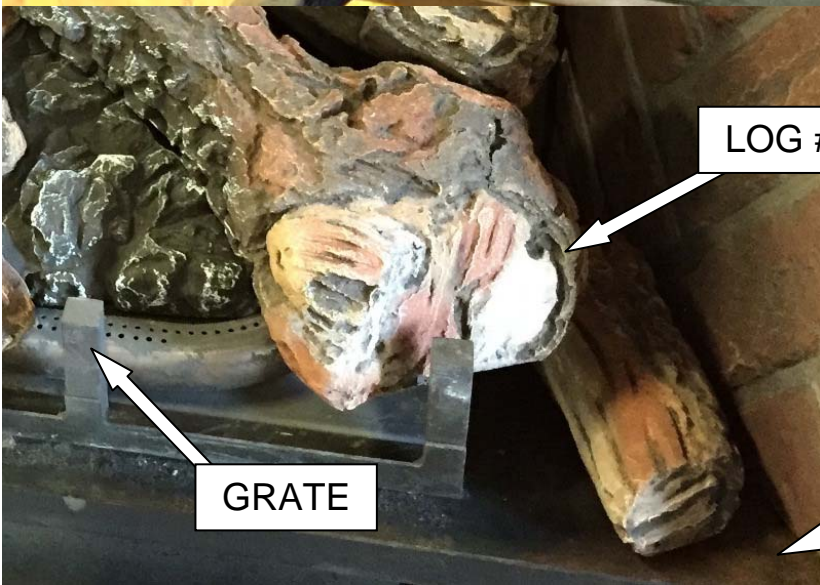

FIREBOX FLOOR

FIREBOX FLOOR

SCATTER SMALL COALS ON THE FLOOR AND BETWEEN THE LOG GRATE'S HORIZONTAL BAR AND THE FRONT BURNER. A FEW COALS MAY SIT ON TOP OF THE FRONT BURNER TUBE BUT AVOID PLACING TOO MANY COALS ON TOP OF THE FRONT BURNER PORTS.

USING A TOOTH BRUSH, BRUSH INSWOOL (GLOWING EMBERS) RANDOMLY OVER LOG #2, THE COALS AND IN AREAS WHERE YOU WISH TO SEE GLOWING EMBER EFFECTS.



**COMPLETED LOG SET ASSEMBLY**

## **FLAME APPEARANCE ADJUSTMENT**

### **AIR SHUTTER ADJUSTMENTS**

Be sure burner and logs are properly installed (see Log Set Installation Section in the Owner's Manual). After burner has been properly installed and operated for 30 minutes, small additional adjustments to the air shutter may be necessary for final flame appearance. These small shutter adjustments can be made by following these procedures:

**NOTE: Start with the rear burner air shutter set at 1/8" open for NG and 3/8" open for LPG. The Rear burner shutter can be manipulated with the fireplace operating.** Opening the shutter will yield shorter and blue(er) flames and closing the shutter will yield taller and yellow(er) flames.

The front burner air shutter adjustment lever is located at the gas entry end of the Front Burner on the right side. Remove the burner and rotate the air shutter cap open or shut for primary air adjustment.

The rear burner air shutter adjustment lever is located in the air gap on the right side of the Glass Door Frame. Locate the Ring Terminal on the right side towards the bottom edge of the Glass Frame. Insert Glass latch tool tip in the Ring Terminal's ring hole. Slide this lever to the "Forward" to Open and to the "Backwards" to close the rear burner shutter.

1. Install logs and glass frame, and burn unit for 30 minutes
2. If flame is too "blue" close Air Shutters until flames turn yellow.
3. If flames are too "orange" or are causing sooting, open Air Shutters until flames begin to turn blue. **NOTE:** If sooting does not stop, turn off fireplace & call a Mendota Service Person.

**IMPORTANT:** Try each new shutter setting for approx. 1/2 hour before making additional changes.

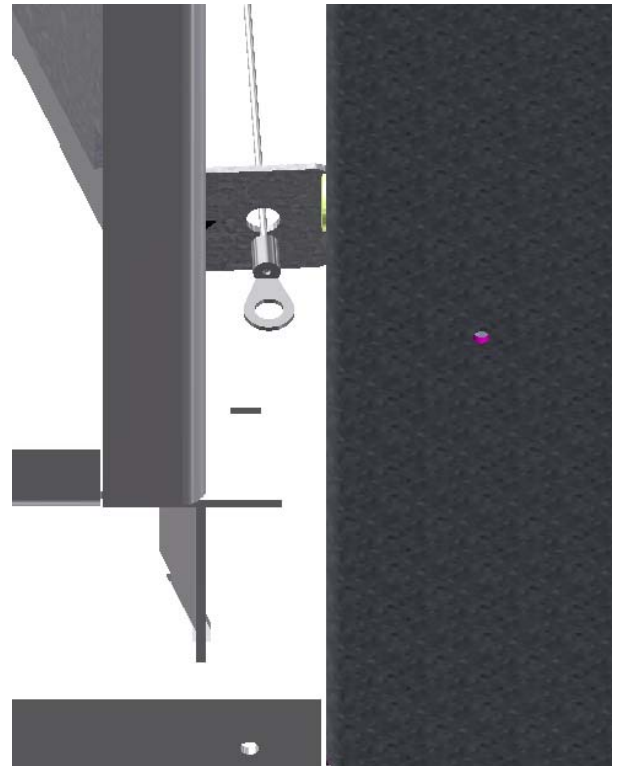

**NOTE:** Changes in front burner flame can be made by re-arranging the coals as well. Densely packed coals will yield more glow and blue flames. Loosely packed coals will yield less glow and yellow flames.

4. For NG applications, start with the rear burner air shutter open 1/8". For high altitude applications, air shutter may need to be open further.
5. For LPG applications, start with the rear burner air shutter open 1/4". For high altitude applications, air shutter may need to be opened further.

# NATURAL TO LP GAS CONVERSION INSTRUCTIONS

Kit # HA-106-00023 Mendota Model FV34-ARCH

## WARNING

This conversion kit shall be installed by a qualified service agency in accordance with the manufacturer's instructions and all applicable codes and requirements of the authority having jurisdiction. If the information in these instructions is not followed exactly, a fire, explosion or production of carbon monoxide may result causing property damage, personal injury or loss of life. The qualified service agency is responsible for the proper installation of this kit. The installation is not proper and complete until the operation of the converted appliance is checked as specified in the owner instructions supplied with the kit.

**Caution:** The electrical supply to the fireplace must be turned off prior to performing the conversion. The gas supply must be shut off prior to disconnecting the electrical power.

## ORIFICE SIZES REQUIREMENT:

A Natural Gas to LPG conversion kit # HA-106-00023 must be ordered and installed in this fireplace insert to burn LPG. LP Conversion Kit # HA-106-00023 contains the following parts: One Motorized LP Pressure Regulator #907.012, and two Cap Orifices #65-14-00364(drill #3/64") and an L-shaped Torx wrench.

## Recommended Procedure to Convert This Fireplace To Burn LPG

This Fireplace Insert arrives from the factory ready to burn Natural Gas. If you intend to burn LPG, it is highly recommended that you convert this fireplace and it's Pressure Regulator, Pilot NG/LP clip position and Burner Orifices prior to placing this fireplace in its fireplace cavity.

See diagrams, on this page, and follow these instructions to prepare this fireplace for conversion to LPG.

1. Using a 1/4" Hex Driver, remove 2 screws that secure the Rear and Front burners to the Burner Airbox.
2. Lift Up and remove Front Burner.
3. Loosen Front Burner Air Shutter Screw and rotate air shutter open 1/4" minimum. Set burner aside.
4. Slide Rear Burner to the right about 2" and lift up and remove from Firebox.

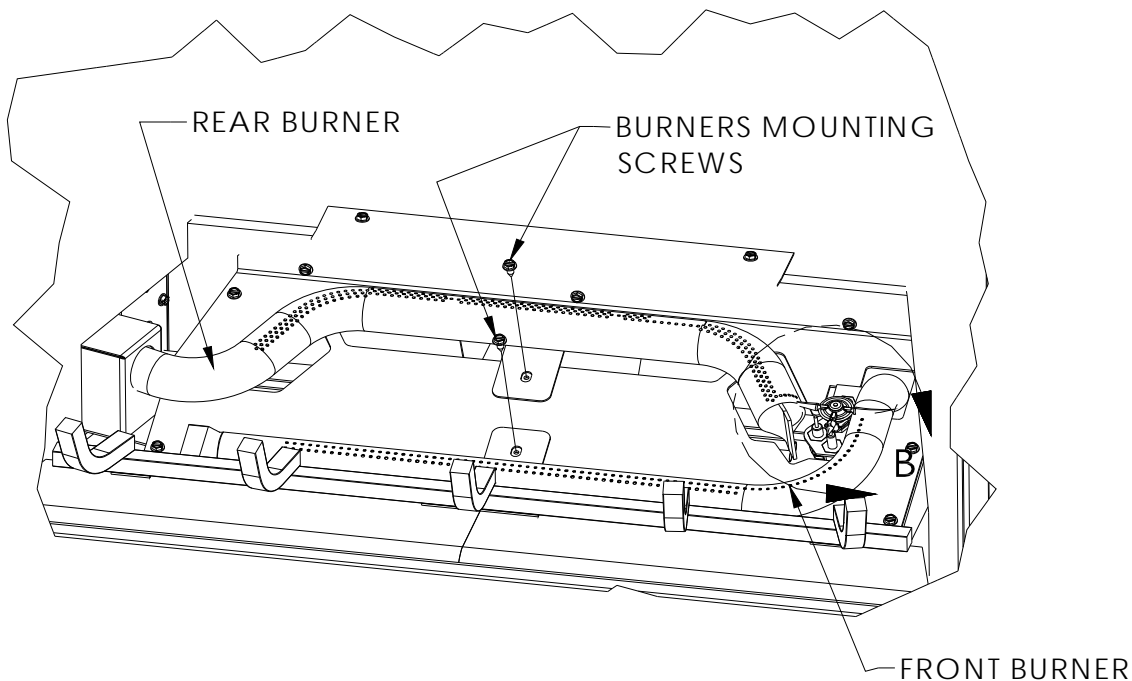
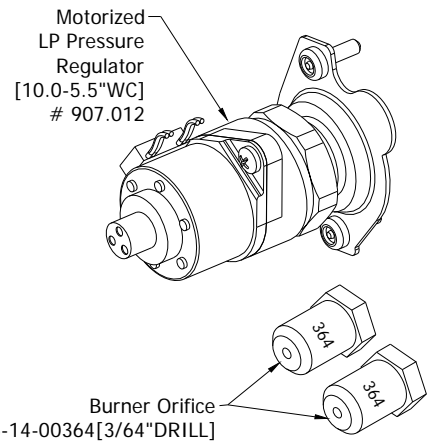

5. Using a 1/2" deep well socket wrench, remove Front and Rear Orifices.
6. Thread a new 3/64" drilled orifice to both Front and Rear Orifice mounting brass fittings. Tighten down orifices.
7. Remove the left-side access panel mounted to the left outer skin and lay down gently without disconnecting any wires of internal components.

### DETAIL C

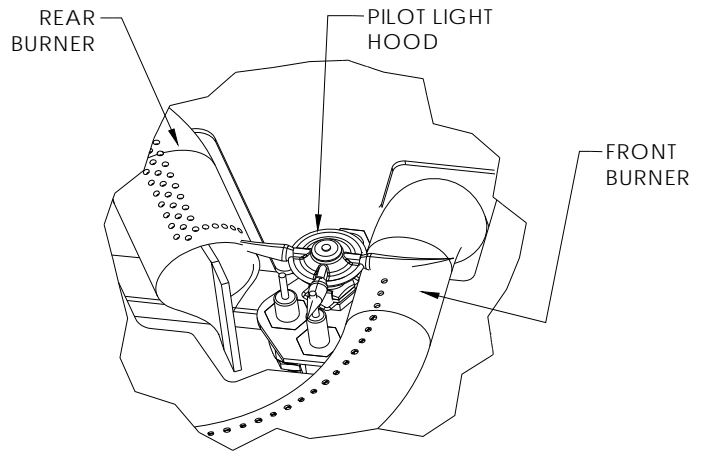
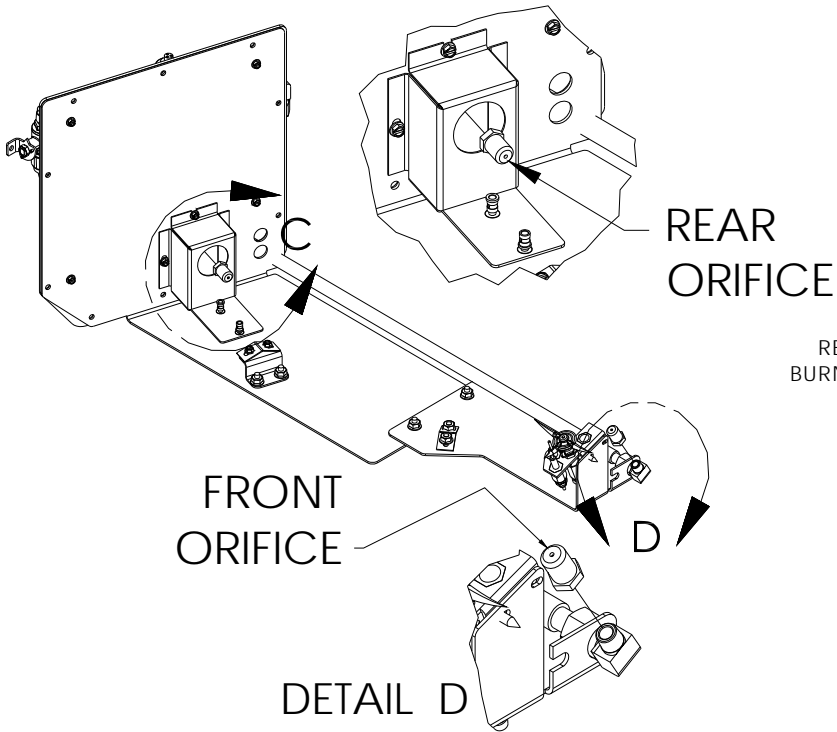

8. Locate Pilot Light on right side of firebox. While holding the pilot base body with large vice grips tightly, loosen Pilot Light's hex shape base using a 1/2" open end wrench. Rotate counter clock-wise 1/4 turn to loosen.
9. Pilot arrives from the factory set for NG. Push NG/LP Adjustment Clip inward all the way to set it for LP. See detail view, below. If you see "NAT" printing on the Adjustment Clip, this indicates that the pilot is set to burn NG. Push Clip in so that "NAT" is not visible.
10. Tighten down Hex shaped base of pilot using a 1/2" open end wrench.

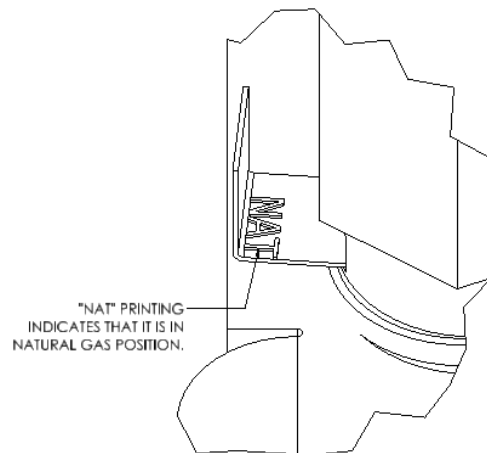
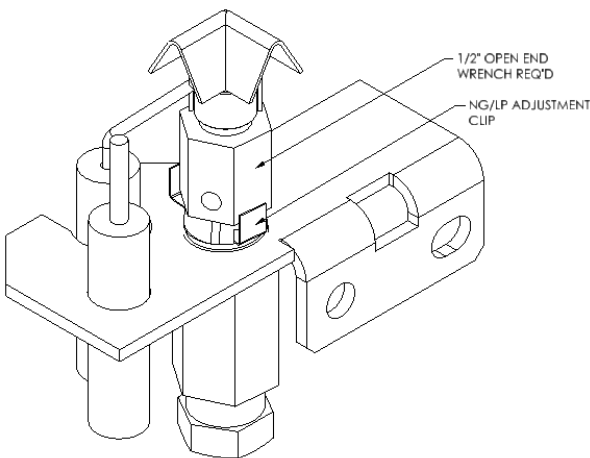

11. Before reinstalling burners, loosen the screw that secures the rotary air shutter on the Front Burner. Rotate the air shutter open to ¼" minimum.
12. Install both rear and front burners in their original locations and positions and secure down using screws you removed earlier.

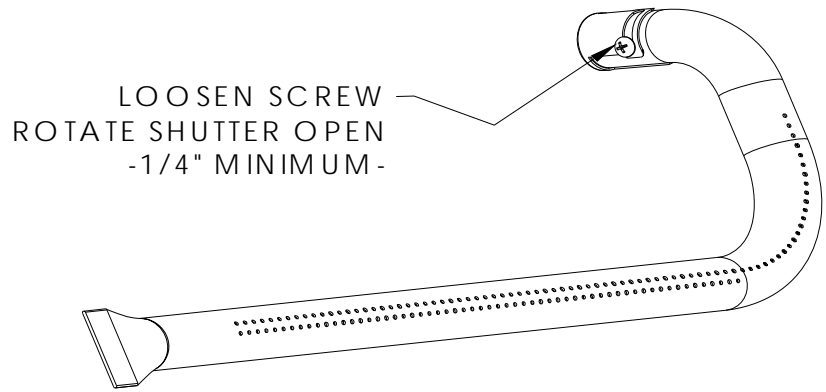

FRONT BURNER SHUTTER ADJUSTMENT

13. Make certain front burner is running parallel to front face of unit positioned properly so that the pilot light hood pointing to the left is pointed properly towards the burner's flame propagation ports.
14. Make certain Rear Burner is positioned properly so that the pilot light hood pointing to the left is pointed properly towards the burner's flame propagation holes.

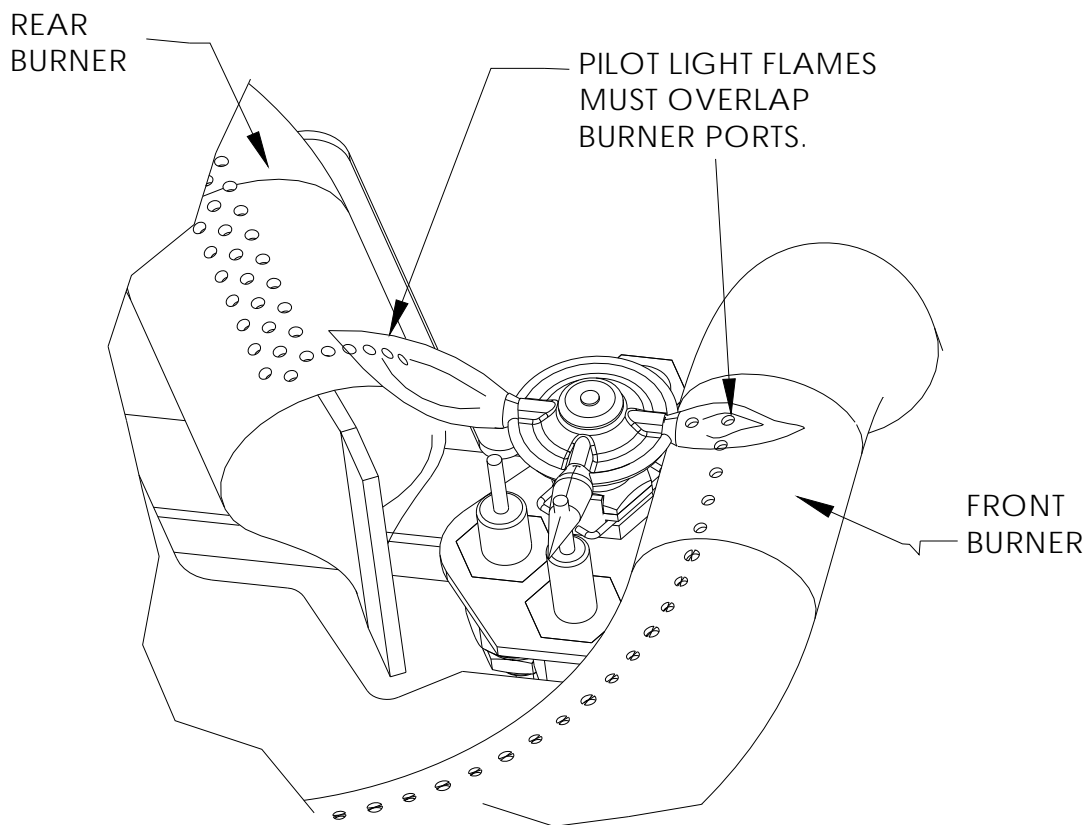



**You must remove the left side Valve Access Panel to replace the pressure regulator.**

15. Remove the left-side access panel mounted to the left outer skin and lay down gently without disconnecting any wires of internal components. **WARNING: DO NOT FORCE. EXCESSIVE FORCE MAY DAMAGE INTERNAL WIRING COMPONENTS!**
16. See diagrams on this page and identify the Pressure Regulator on the Valve Body. Remove the left side Controls Access Panel. Gas Valve and the Pressure Regulator Mounted on the Gas Valve are accessible through the opening on the left side.

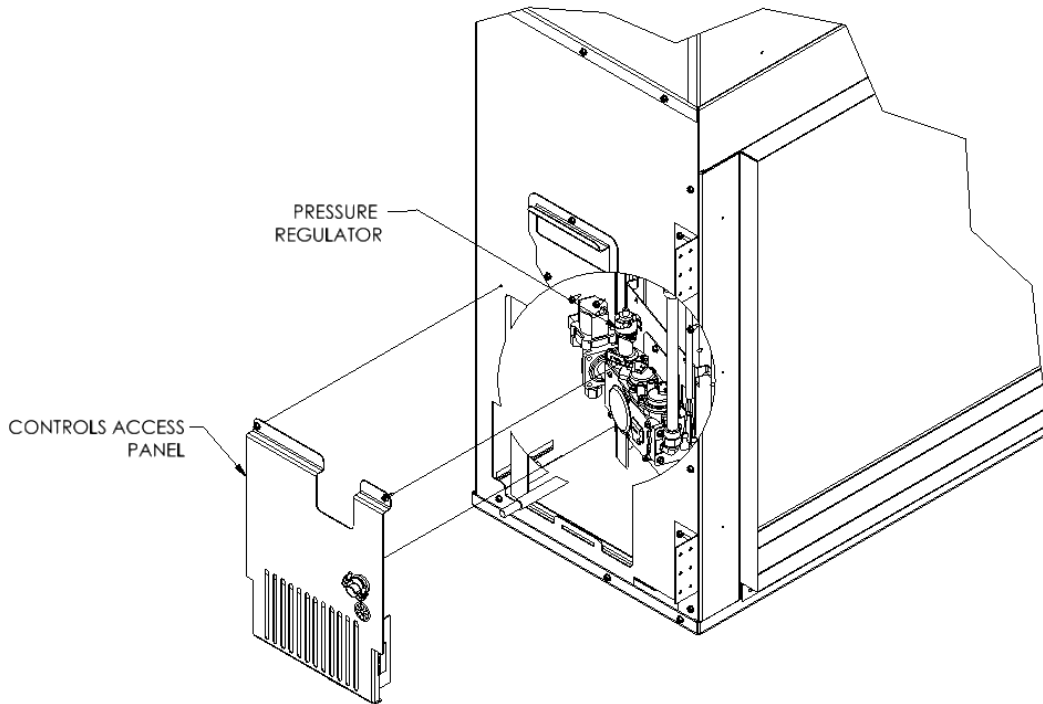

17. Using a Torx T20 (supplied) or a slotted screwdriver, remove 2 screws that secure the NG Pressure Regulator to the gas valve body and remove NG Pressure Regulator, see following page for detailed instructions. Note: Be careful when removing or tightening the screw on the back-side of the pressure regulator. The screw location is difficult to access and care must be taken to ensure a proper seal when tightened.
18. Install the new LP Pressure Regulator onto the gas valve body in the same position and orientation as the NG Pressure Regulator you removed in Step 2, above. The LP Pressure Regulator can only be mounted in one position. Secure the LP Pressure Regulator in place. Tighten down.

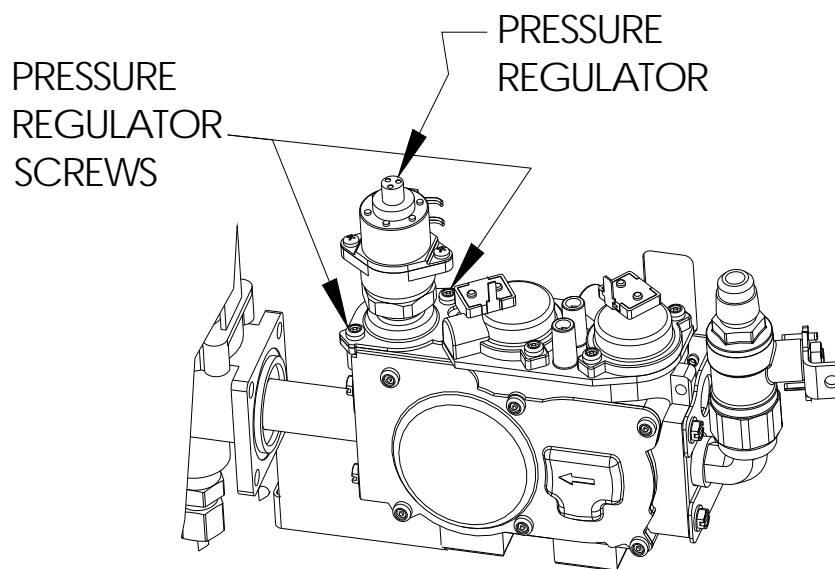

## LP PRESSURE REGULATOR CONVERSION INSTRUCTIONS

**WARNING:** Failure to position the parts in accordance with these diagrams or failure to use only parts specifically approved with this appliance may result in property damage or personal injury.

### WARNING!

The installation of this conversion kit must only be undertaken by a qualified and certified gas appliance installer.

### STEPPER MOTOR PRESSURE REGULATOR CONVERSION KIT INSTALLATION OR REPLACEMENT INSTRUCTIONS.

Verify that the following items are present in the package.

- Pressure regulator assembly (E)
- Two (2) screws (F)
- Identification label (G)
- Installation instructions (this document).

- 1 Shut off the gas supply to the valve and shut down the electric supply.
- 2 See Fig. 1. Using a Torx T20, or slotted screwdriver, remove and discard the two (2) pressure regulator mounting screws (A), pressure regulator tower (B), and the spring and diaphragm assembly (C), (If applicable).
- 3 Ensure the rubber gasket (D), which is prefitted as part of assembly (E), is properly positioned, see Fig. 2, otherwise fit the gasket as shown Fig. 2.
- 4 Install the new STEPPER MOTOR pressure regulator assembly, as shown in Fig. 3 and Fig. 4. Use the supplied screws (F), M4 x 0.7 threaded, length of thread  $L=(16\text{ mm} + 0 - 0.5\text{ mm})$ , steel material, resistance class 8.8 (see Fig. 5).
- 5 Manually thread the two conversion kit mounting screws into the valve body. Use a standard screwdriver or T20 Torx bit and tighten to the screws with a fixing torque of  $25\text{lb-in} \pm 5\%$ .  
IN THE EVENT THAT THE THREADS OF THE VALVE ARE STRIPPED OR DAMAGED, REPLACE THE VALVE.
- 6 Install the enclosed identification label (G) to the valve body where it can be easily seen.
- 7 Make STEPPER MOTOR and valve electrical connections, apply gas to system and relight appliance according to manufacturers instructions.
- 8 With the main burner "ON", test the new pressure regulator assembly for leaks using a soap solution.
- 9 Relight the main burner and verify proper burner ignition and operation.

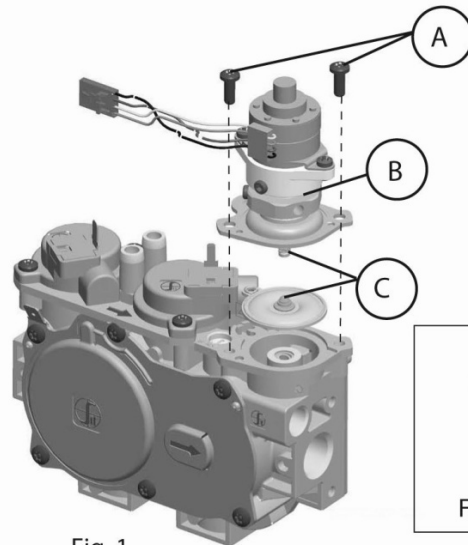

Fig. 1

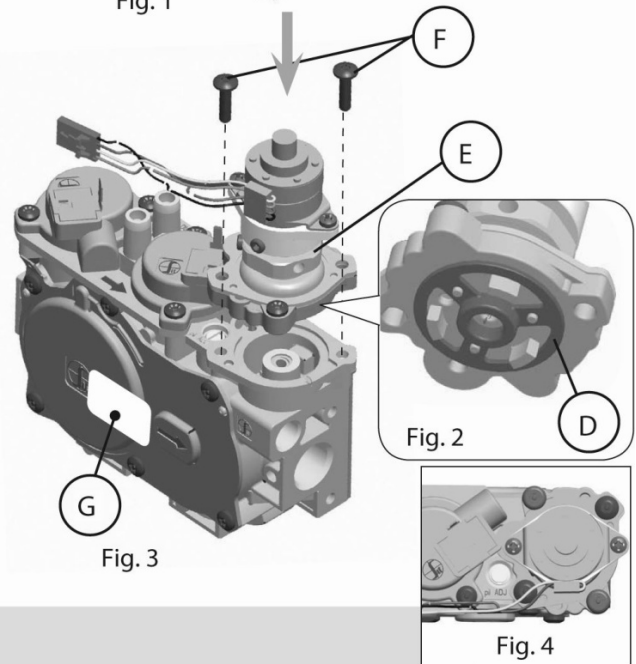

Fig. 3

Fig. 4

### WARNING!

Installation should be carried out in a clean environment.

### WARNING!

This modulating conversion kit must ONLY be applied as part of a conversion kit supplied by the APPLIANCE MANUFACTURER for the specific appliance, and type of gas, being converted.

### WARNING!

Correct operation of the system cannot be guaranteed if the conversion kit or valve has been dropped or has sustained a strong impact.

INSTALLER NOTICE. These instructions must be left with appliance.

## LP GAS PRESSURE REQUIREMENTS

Inlet and manifold gas pressure checking taps are located on gas valve. These ports are only accessible from the outer left side of the fireplace. A qualified installer shall take pressure measurements at these ports to verify and set the correct gas pressures during the LP Kit installation and before fascia materials are installed over the front of this fireplace. Manifold pressure must be taken at the "MANIFOLD PRESSURE" tap and inlet pressure at the "INLET PRESSURE" tap **with the burner operating** by a qualified installer.

	DESIRED INLET PRESSURE	MINIMUM INLET PRESSURE	MAXIMUM INLET PRESSURE	MANIFOLD OUTLET PRESSURE	AIR SHUTTER POSITION
L.P. GAS	12.0" W.C. (2.98 kPa)	12" W.C. (2.98 kPa)	13.0" W.C. (3.24 kPa)	10.0" W.C. (2.5 kPa)	1/4" OPEN MIN. (5 mm)

**REGULATE THE FLAME HEIGHT TO "HIGH" POSITION. OUTLET GAS PRESSURES MAY VARY PLUS OR MINUS 5%.**

### LPG PROPER INPUT RATES:

With the proper orifices installed, as specified above, this fireplace utilizing LP Gas will have a maximum input rate of 31,500 Btu/Hr.

### LEAK TESTING REQUIREMENTS

Prior to completing the conversion process, check for gas leaks with soap and water solution at all plumbing joints prior to placing this appliance into operation. It is recommended that all gas-plumbing joints, factory installed and field installed are checked for leaks.

### PILOT FLAME AND MAIN BURNER RELATIONSHIP VERIFICATION

Prior to completing the conversion process, the qualified service technician must, light the pilot light and verify the relationship between the pilot light flames and the main burners. The pilot light flames directed towards the propagation ports on the rear and front burner must overlap the propagation ports on the burners. The pilot light flames must be a minimum of 3/4" long and must overlap the propagation ports on both the rear and front burners as shown in the diagram, below. Verify that the burner tubes ignite quickly and the burner flames propagate smoothly along the entire length of the burners.

### PILOT FLAME LENGTH ADJUSTMENT

If the pilot light flame length is too short and the system does not maintain a standing pilot, a qualified installer may increase the length of the pilot light flames to meet the two requirements: Minimum pilot light length to maintain a standing pilot light and the pilot light flames must be long enough to overlap the front and rear burner ports.

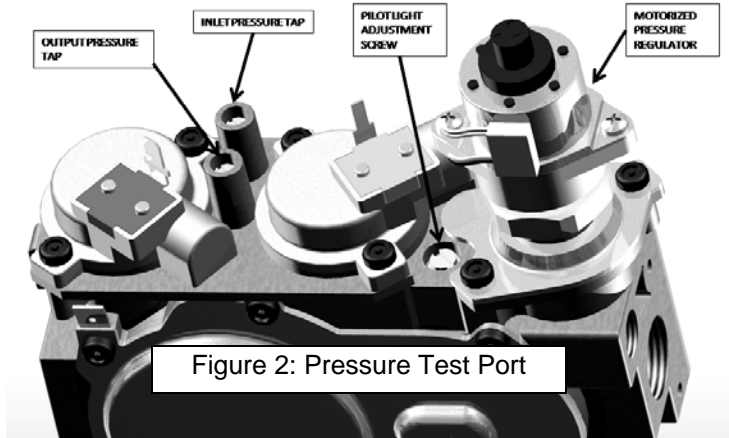
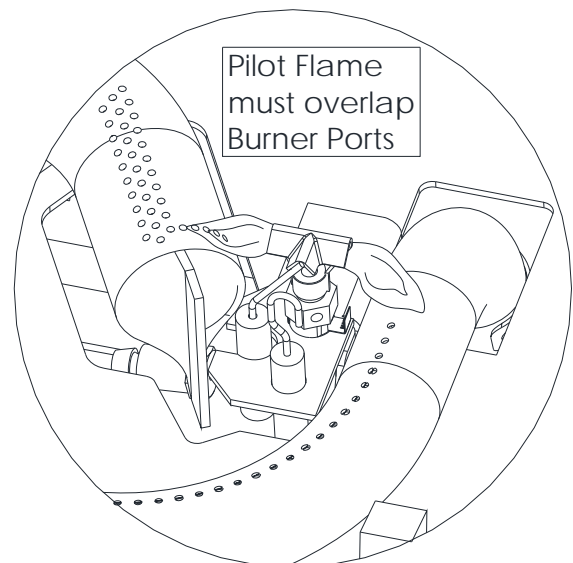
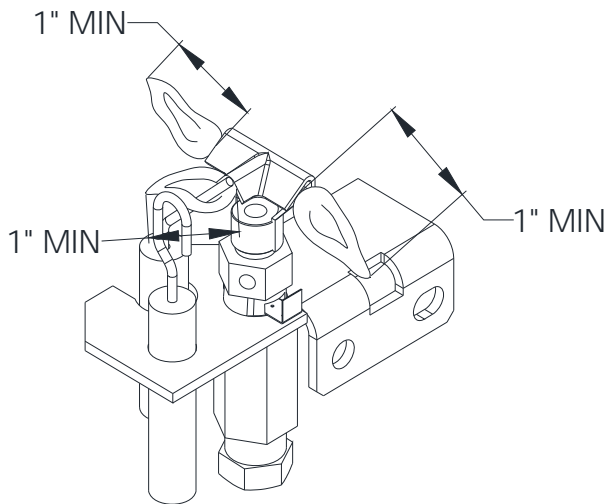

Figure 2: Pressure Test Port



## **GAS INPUT RATE VERIFICATION REQUIREMENTS**

### **Natural Gas Applications Gas Input Rate Verification Procedures**

Verify Main Orifice Size. The main orifice body has the orifice hole size stamped on it. NG orifice size shall be #44" (Rear Burner) and # 49 (Front Burner) for all elevations.

Verify that the Manifold Gas Pressure is within 3.5" WC +/- 1/8".

Once setup, read the main home gas supply meter reading.

Write the initial reading here >> Initial Gas Meter Reading \_\_\_\_\_

Turn OFF all other appliances and their pilot flame in the home.

Run this appliance for a period of 30 minutes on maximum flame size. Turn off main burner and pilot flame.

Read the main home gas supply meter reading after the 30 minutes of burn time.

Write the reading here >> Final Gas Meter Reading \_\_\_\_\_

Calculate the following:

FINAL GAS METER READING - INITIAL GAS METER READING... Subtract Initial Gas Meter from Final Gas Meter Reading. This will yield the number of Therms used during the 30 minute burn time.

Multiply the result in Item 11 by 100,000.

Multiply the result in Item 12 by 2. Write down the Result here >> \_\_\_\_\_

The result in item #13 shall be at least maximum Input Rate (31,500 Btu) for altitudes below 2000 Feet. For altitudes higher than 2000 feet, the result in item #13 shall be at least 31,500 Btu.

### **LPG Applications Gas Input Rate Verification Procedures**

Verify Main Orifice Size. The main orifice body has the orifice hole size stamped on it. LPG orifice size shall be 3/64" (Front and Rear Burners) for 0-2000 feet elevation and 3/64" Front Burner and #55 Rear Burner for elevations exceeding 2000 feet.

Verify that the Manifold Gas Pressure is within 10.0" WC +/- 1/8".

### **CHECKING FOR NORMAL BURNER (S) IGNITION CHARACTERISTICS**

Once the conversion to LPG and all the above steps have been completed, light the main burners.

Use Remote Transmitter to turn on Pilot Light and burners. Main burner should now light IMMEDIATELY and flame should not "lift" off burner. If there is any delay in ignition or if flame is "lifting off" burner, turn off burner and carefully check for proper installation of logs/coals, vent system and proper pilot flame impingement on burner. Logs or coals must not block pilot flame or main burner flame. Vent system must be leak proof.

#### **WARNING**

**DO NOT PROCEED WITH OPERATION OF THIS FIREPLACE  
UNLESS BURNER "CYCLES" ON/OFF WITHOUT DELAYS!**

### **ATTACHING LPG CONVERSION LABELS AND HIGH ALTITUDE DERATION LABEL**

Two printed informational labels are included with the LPG Conversion Kit. Attach these two labels to the back surface of the Serial Number Plate that is located in the convection air cavity below the firebox. If you are derating this appliance at a high altitude, also attach the High Altitude Deration Label, supplied in the Owner's Manual Packet, to this same surface.

Prior to attaching the labels, fill in all the information that is requested in these labels.

For installations from 610-1370 meters (2000-4500 ft.) the orifice sizes (DMS) for Natural Gas are #44(rear) and #49(front) and Propane Gas are #55(rear) and 3/64"(front), respectively. See data plate for additional information. For high altitude installations consult the local gas distributor or the authority having jurisdiction for proper rating methods. If the installer must convert the unit to adjust for varying altitudes, the information sticker must be filled out by the installer and adhered to the appliance at the time of conversion."

«Cet appareil est équipé pour des altitudes comprises entre 0 et 2000 pieds (0-610 m) seulement»

This appliance has been converted for use at an altitude of \_\_\_\_\_

Orifice size \_\_\_\_\_ Manifold Pressure \_\_\_\_\_

Input (Btu/h) \_\_\_\_\_ Fuel Type \_\_\_\_\_

Date of conversion \_\_\_\_\_ Converted by \_\_\_\_\_

«Cet appereil a été converti au \_\_\_\_\_

Injecteur \_\_\_\_\_

Pression à la tubulure d'alimentation \_\_\_\_\_

Déoit calorifique \_\_\_\_\_

## Remote Control Transmitter Functions

**NOTE:** The Ignition Module Receiver will “beep” once every time a Remote Transmitter Key is pressed, signaling that the command has been received.

Identify the four function buttons on the Remote Transmitter:

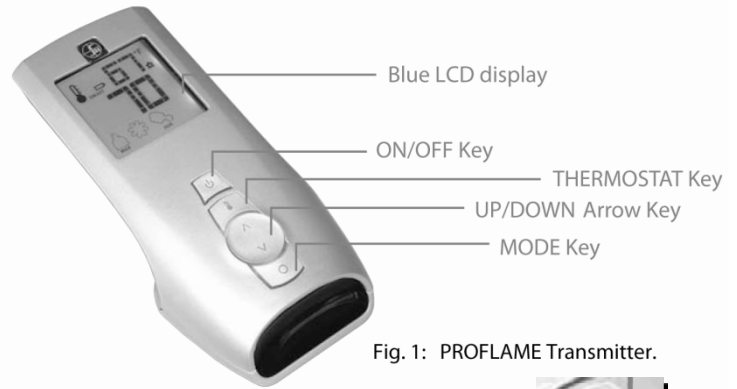

Fig. 1: PROFLAME Transmitter.

1. **ON/OFF KEY:** This button turns the system ON or OFF. When this button is pressed and the system is OFF, the pilot light will stay ON if the “Standing Pilot Switch” is in the ON position.



2. **THERMOSTAT KEY:** This button, when pressed after the ON/OFF KEY is pressed and the system is ON, will allow the selection of three modes: Manual Operation, Normal Thermostat and Smart Thermostat.



- a. **Manual Mode:** In this mode, the room temperature is ignored and the fireplace can be turned ON indefinitely. The room temperature rise has no effect on this mode. All other functions such as fan speed control, flame height control, secondary burner On/OFF control and Accent Light ON/OFF controls will be manually controllable.

- b. **Normal Thermostat:** In this mode, the fireplace will stay functioning until the room temperature increases 1°F above the Set Point Temperature. To increase the Set Point Temperature, Press the UP button until the desired temperature is displayed in the SET POINT TEMPERATURE window. The fan will turn on 5 minutes after fireplace startup and will turn off 12-1/2 minutes after the flames turn off, in this mode. The flame height can be adjusted while the fireplace is functioning, fan speed can be adjusted after 5 minutes of startup. Secondary burner can be turned On or Off at any time after startup. The Accent Light can be turned on or off any time after startup.

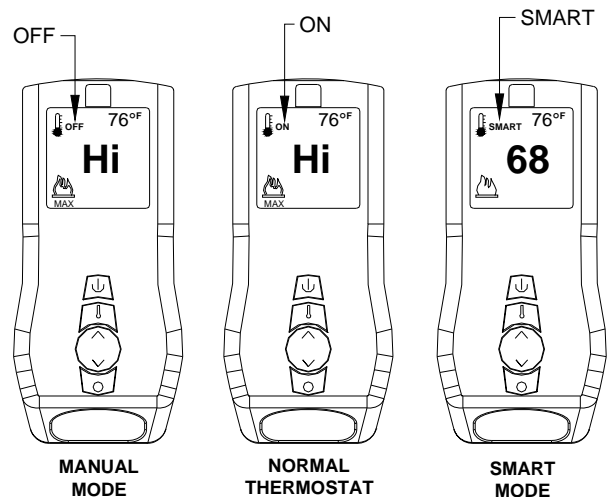

- c. **Smart Thermostat:** In this mode, all other functions except the flame height adjustment are allowed. Manual flame height adjustment is not allowed in this mode. The Smart Thermostat function adjusts the flame height in accordance to the difference between the set point temperature and the actual room temperature. As the room temperature gets closer to the set point temperature, the Smart Function automatically modulates the flame down.

3. **UP/DOWN KEY:** This key is used to increase or decrease the Set Point Temperatures, Flame Height and Fan Speed and to toggle between Accent Light ON/OFF and Secondary Burner ON/OFF.



4. **MODE SELECTION KEY:** This key is used to toggle between the various function icons : Flame Height, Fan Speed, Accent Light and Secondary Burner.



## REMOTE TRANSMITTER OPERATING INSTRUCTIONS

### TO TURN ON THE APPLIANCE:

1. Press the ON/OFF button. The transmitter display will show all active icons on the screen.
2. Select the Thermostat Mode by pressing the Thermostat Key: OFF (meaning Manual Mode), ON (meaning normal Thermostat) or Smart (meaning Smart Mode).
  - a. In OFF (Manual Mode), the appliance will ignite and start on HI.
  - b. In ON (Normal Thermostat Mode), the appliance will only ignite if the Set Temperature is greater than the Room Temperature.
  - c. In SMART (Smart Mode), the appliance will only ignite if the Set Temperature is greater than the Room Temperature.



### TO TURN OFF THE APPLIANCE, press the ON/OFF button.



**MODE KEY:** Pressing the MODE KEY toggles between the various available functions: Flame Height, Fan Speed, Accent Light Dimmer and Secondary Burner On/Off.

**Flame Height:** 6 flame height Levels are available. While the Flame Height Icon is displayed, pressing the Up or Down button once will increase or decrease the flame height by 1 of 6 increments. If the flame height is at Level 1 and the Down button is pressed, all burners will turn OFF. If in IPI mode, the pilot light will also extinguish. If in Standing Pilot Mode, the pilot light will remain ON. Note: If in SMART model, the flame height function is not available for manual adjustment. In SMART mode, the flame height regulates automatically.



FLAME HEIGHT

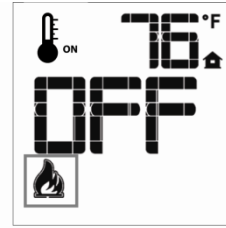

Flame Off

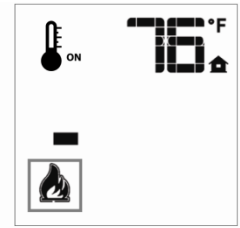

Flame Level 1

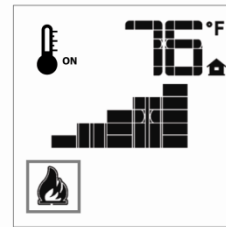

Flame level 5

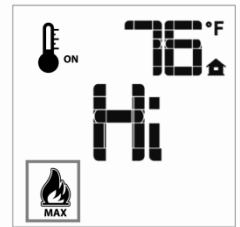

Flame Level Maximum

**Fan Speed Control:** The fan speed can be adjusted through six (6) speeds and OFF. To activate this function, press the MODE Key to index to the fan control icon. Use the UP/Down Arrow Key to turn ON, OFF or adjust the fan speed. A single “beep” will confirm reception of the command. Once you set the desired fan control, the system will remember your selected fan speed until you manually change it.



FAN SPEED

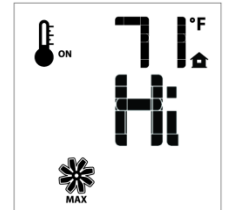
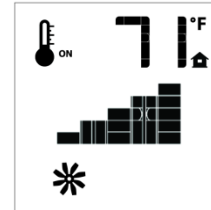

**Accent-Light Dimmer:** This function controls the Mendota Accent Light functions. Pressing the UP key in this mode will TURN ON the Accent Light and allow you to control the brightness of the Accent Light in 6 steps. A single “beep” will confirm reception of the command. Once you set the desired light brightness, the system will remember your selected brightness level until you manually change it.

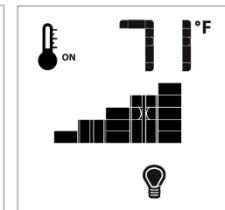
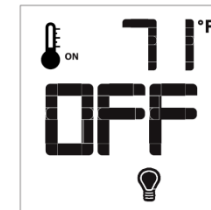

**Secondary Burner:** This function controls the Secondary Burner's ON/OFF feature. Pressing the UP Key in this mode will TURN ON the Secondary Burner and Pressing the DOWN Key will TURN OFF the Secondary Burner. The flame level will not change when you turn the Secondary Burner On or Off. The flame level can only be changed in the Flame Level mode.



2nd BURNER

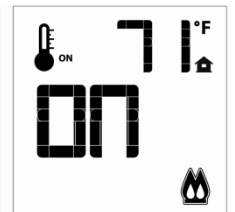
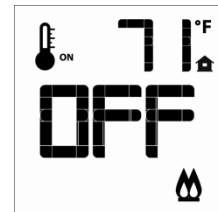

### TEMPERATURE INDICATOR (°F or °C)

1. Press the ON/OFF Key and Turn Off the Fireplace.
2. Simultaneously, Press both the MODE Key and the Thermostat Key.
3. Look at the LCD display to verify that your desired indicator (°F or °C) is being displayed. If not, repeat step 2.

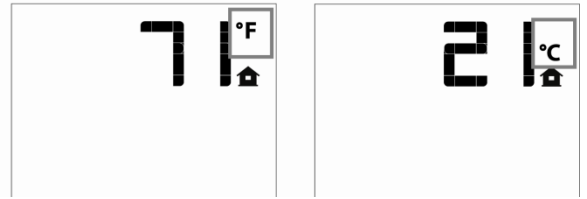

### KEY LOCK FUNCTION

To prevent unsupervised children from operating the fireplace, a KEY LOCK function is provided with this remote control system. To activate the KEY LOCK function, simultaneously press the "MODE KEY" and the "UP KEY". To deactivate the KEY LOCK function, simultaneously press the "MODE KEY" and the "UP KEY".

During KEY LOCK mode, none of the Keys will function. You must DEACTIVATE the system before you can use the Remote Transmitter.

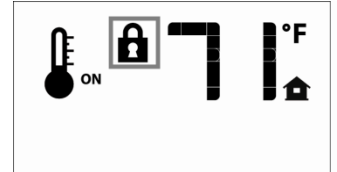

### LOW BATTERY POWER DETECTION

1. **Transmitter Batteries:** The life span of the remote control transmitter batteries depends on various factors: quality of the batteries used the number of ignitions of the appliance, the number of changes to the room thermostat set point, etc. When the Transmitter batteries are low, a Battery Icon will appear on the LCD display of the Transmitter before all battery power is lost. When the batteries are replaced, this icon will disappear.

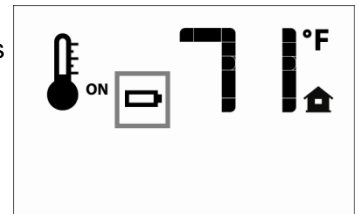

### OPERATING DURING POWER OUTAGES

This electronic ignition system utilizes the supplied 110VAC power when it is available for all functions of this system. If the AC power is interrupted during a power outage, plug in the battery pack (supplied with this fireplace) to the Fireplace Backup Power Inlet Port installed on the wall to the left side of the fireplace (located about 18" up from floor level).

During the power outage, the appliance's burners will function. In addition, Flame Height adjustment and Secondary Burner ON/OFF functions will be available. The Fan and Accent Light, which are wholly dependent on 110VAC power, will not function.

This appliance is designed and tested to be operated during power outages. The overall efficiency of this appliance will be reduced by approximately 5% when the blower function is disabled during the power outage period.

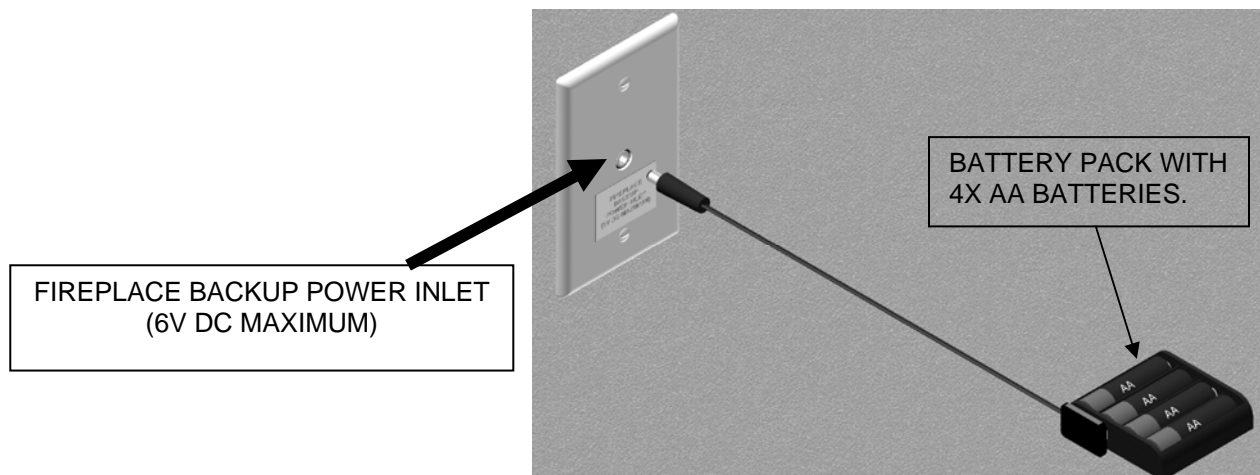

## “FIRST TIME” PILOT LIGHTING INSTRUCTIONS

**IMPORTANT:** Be sure all items on "INSTALLATION CHECK OFF LIST" in the Installation Manual have been completed!

**CAUTION:** If the pilot goes out, be sure to wait a minimum of five minutes before attempting to relight the pilot.

1. Make certain that any manual gas supply shut-off valves located upstream of fireplace are open and the Master On/Off switch is toggled to the ON position.
2. Make certain that 110VAC power is connected to Electrical Junction Box on left side of Fireplace and that the Electrical Power is "ON".
3. Insert Batteries in the Remote Transmitter. Note the polarity of batteries and insert as indicated on the battery compartment cover.
4. For the "First Time Lighting", Remove the Glass Door. This is required to purge the gas line of air and to inspect the pilot lighting spark.
5. Press OFF on the remote Transmitter. Press MODE button on Transmitter. Press UP for "CPI" (standing pilot mode). Press MODE button again to exit. You will hear a series of clicks and after a few seconds, you will hear sparking at the pilot spark electrode.
6. Allow adequate time for the air in the gas-line to purge. The control system will stop sparking after 30 seconds if the pilot light does not light. After a 30 second delay the control system will start sparking again for 30 seconds more. If the pilot light does not light after the third 30 second spark event, the system will enter "Lock-out" mode. To unlock from "Lock-out" mode, Press the ON/OFF button on Transmitter then Press ON/OFF button on the transmitter again so the Transmitter display turns off. Wait 30 seconds. Turn OFF the Master Switch. Wait 30 seconds and Turn Master Switch ON again. Repeat this sequence until the pilot flame lights and the pilot is burning steadily.
7. Once the pilot flame is lit and well-established, close glass door. **WARNING: NEVER IGNITE MAIN BURNERS WITH GLASS DOOR REMOVED OR OPEN. Doing so will lead to damage to pilot flame sensor and spark electrode wire leads.**
8. Press the ON/OFF button on Transmitter to "ON". All burners should ignite and run at "high-fire". Toggle through other functions of the Fireplace (Flame Height, Fan Speed and Accent Light brightness) to verify all functions.
9. Perform gas inlet and outlet pressure tests and leak tests on field installed gas fittings and factory installed fittings in the gas valve compartment, at this time. Note: Burners must be ON to check outlet pressures and to leak test gas train fittings upstream of main gas valve.

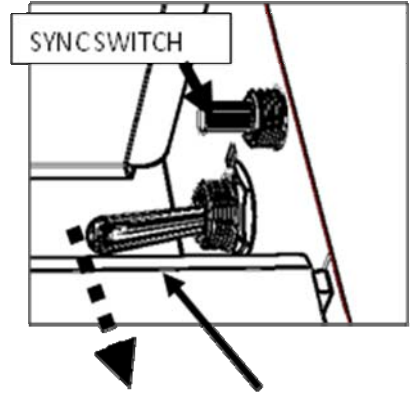

MASTER SWITCH ON

### INITIALIZING THE REMOTE CONTROL SYSTEM

**MASTER SWITCH:** Remote Transmitter WILL NOT communicate to receiver unless the Master Switch is ON. The master switch when OFF disable all functions and acts as a Master Safety Shutoff Switch.

#### (Synchronizing Receiver and Transmitter)

Master Switch and Sync Switch are located at the bottom right corner of the Glass Frame.

1. Toggle Master Switch to ON (pull toward front of unit). Remote Transmitter WILL NOT communicate to receiver unless the Master Switch is ON.
2. Locate Sync Switch (directly above Master Switch). Press the Sync Button. The receiver will beep 3 times indicating that it is ready to synchronize with a Remote Transmitter.
3. Push the "ON" key on the Remote Transmitter. The receiver will beep 4 times to indicate that the Transmitter's command is accepted and sets to the particular code of that Transmitter. The system is now initialized.

**NOTE:** Once synchronized, the Transmitter and Receivers will communicate permanently and no further Synchronizing steps are necessary unless either the Transmitter or Receiver is replaced.

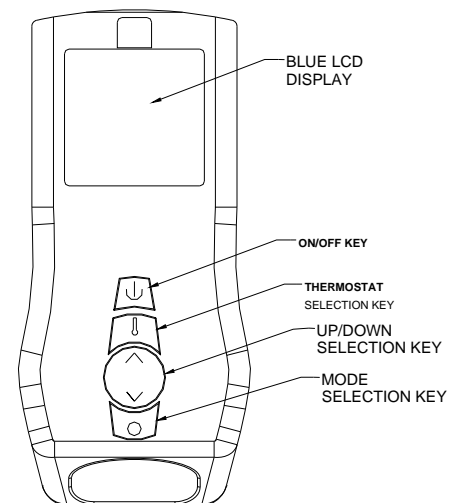

REMOTE TRANSMITTER

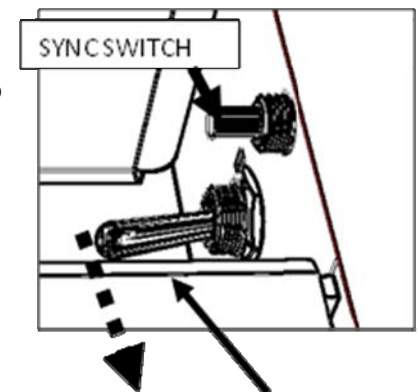

MASTER SWITCH ON



## IPI/STANDING PILOT SYSTEM INFORMATION

	REMOTE CONTROL	IGNITION MODULE/ RECEIVER
Supply voltage	4.5V (three 1.5V AAA batteries)	6.0V (four 1.5V AA batteries)
Ambient temperature ratings	32 – 122 °F (0 – 50 °C)	32 – 140 °F (0 – 60 °C)
Radio Frequency	315 MHz	315 MHz

### **ATTENTION!**

- The transmitter and receiver are RADIO FREQUENCY DEVICES.
- Turn off the main gas supply of the appliance during installation or maintenance of the receiver.
- Toggle the Master Switch to OFF during installation or maintenance.
- During appliance installation/maintenance or in case of remote control malfunction, turn off electrical supply to this appliance and disconnect the Backup batteries from the wall DC connector. Contact technical service.

### **Intermittent Pilot Light and Standing Pilot Light Features**

This gas fireplace is equipped with an electronic ignition System that first lights a pilot light then uses the pilot light to ignite the main burners. The pilot light can be set in the CPI (Standing Pilot) mode to allow the pilot light to remain on indefinitely by setting the Remote Transmitter to CPI mode. If the remote transmitter is set to the IPI (Intermittent Pilot) mode, the pilot light will only light and remain ON while the main fireplace burners are operating.

IPI Mode: This mode turns the pilot light “OFF” when the fireplace is not functioning and only lights the pilot light automatically when a call for heat is made by the remote control.

**(CPI) Standing Pilot Mode: If set to CPI Mode, the pilot light will ignite and remain ON at all times.**

#### **Setting to IPI versus CPI mode:**

With the remote transmitter OFF, press the MODE button. You will see either “CPI” or “IPI” displayed on the transmitter screen. Press the UP arrow button to set “CPI” mode and press the DOWN arrow button to set “IPI” mode. One set to the desired setting, press On/Off button to activate the fireplace.

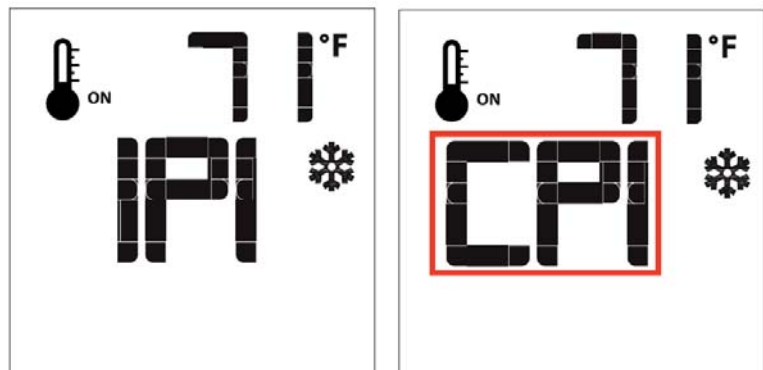

**NOTE: Mendota Fireplaces recommends that the (CPI) Standing Pilot Mode be used during the winter months when the average daily high temperature falls below 50°F.** This will keep the fireplace chimney heated for proper up-draft during burner ignition and it will also eliminate excessive condensation of exhaust vapors on the door glass. Further, leaving the fireplace in the Standing Pilot Mode will keep the fireplace body warm and eliminate cold drafts and heat loss to the cold air that is trapped inside the firebox.

## REPLACEMENT PARTS

### FV34-ARCH VALVE ASSEMBLY REPLACEMENT PARTS

ITEM	QTY	PART NUMBER	DESCRIPTION
1	1	HA-97-00028	VALVE HEAT SHIELD, FV34
2	1	05-02-00344	VALVE, 885 PROFLAME (NG) SIT# 0.885.001
3	1	05-02-00351	SPLIT-FLOW, PROFLAME, SIT# 0.540.002
4	1	65-07-00744	Ball Valve
5	1	65-14-00045	ORIFICE, #45 17,072 BTU NAT
6	2	65-07-00012	BCF,3/8 TBE X 3/8MPT COMP ELBW
7	1	HA-81-00419	SHUTTER BOX SLIDER, FV33i
8	2	65-06-00577	CABLE NUT, ASSY
9	1	65-07-00010	BCF,3/8 TBE X 1/8MPT COMP ELBW-AF
10	1	HA-81-00408	VALVE BRACKET, FV33i
11	1	60-01-00257	NIPPLE, 3/8" NPT X 2.0" LONG, 0.493 ID, BLACK
12	1	55-02-00098	TUBING, 3/8" OD x 27" SS 304
13	1	55-02-00083	3/8" SS Flex Tube X 6" T6-06
14	1	65-14-00049	ORIFICE, #49 13,530 BTU NAT
15	1	65-05-00040	ELBOW,3/8"X90 DEG STREET,BLACK
16	1	HA-97-00086	HEAT SHIELD, INNER
17	2	65-14-00364	ORIFICE, 3/64"
18	1	05-04-00065	PILOT, 3-WAY HOOD
19	4	50-01-00252	SCREW, HEX WASHER, 8-32 X 3/8", TYPE 23, ZINC

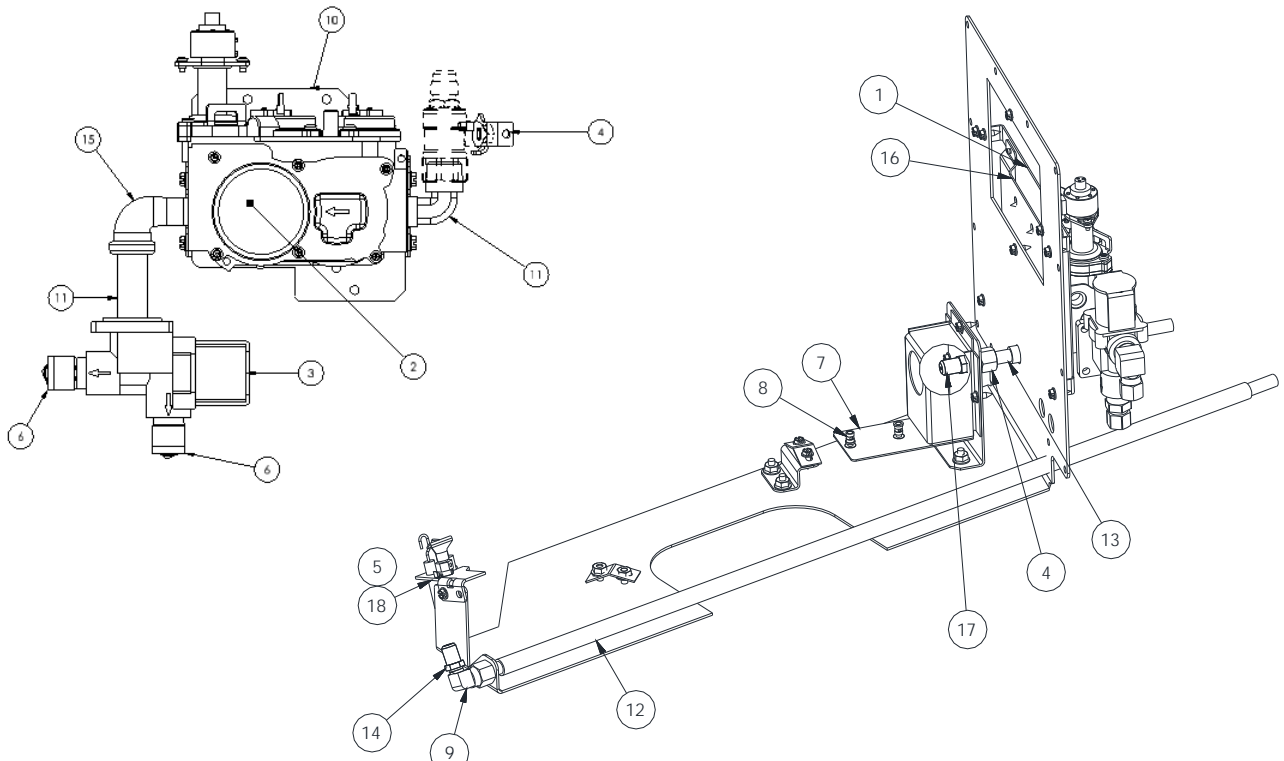

# FV34-ARCH GAS IGNITION SYSTEM WIRING DIAGRAM

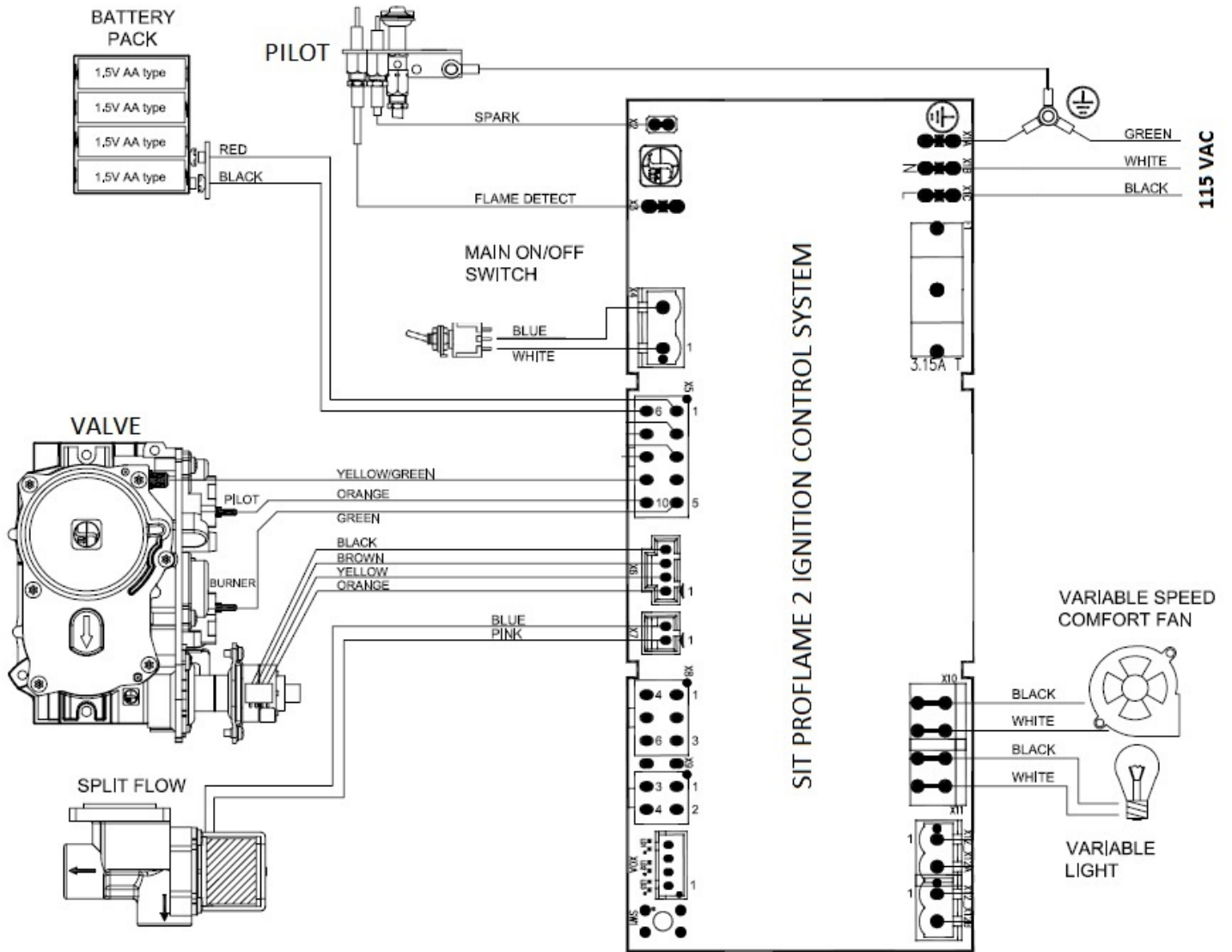

## NOTES:

-CONNECT WIRES IN JUNCTION BOX ON THE LEFT SIDE OF THE FIREPLACE TO HOUSE POWER USING THE SUPPLIED WIRE NUTS.

-REPLACEMENT WIRE MUST BE OF THE SAME SIZE AND TYPE OF INSULATION AS ORIGINAL.

-THE APPLIANCE MUST BE ELECTRICALLY CONNECTED AND GROUNDED IN ACCORDANCE WITH LOCAL CODES OR, IN THE ABSENCE OF LOCAL CODES, WITH THE CURRENT NFPA 70-NATIONAL ELECTRIC CODE OR CSA C22.1-CANADIAN ELECTRICAL CODE.

-LABEL ALL WIRES PRIOR TO DISCONNECTION WHEN SERVICING CONTROLS. WIRING ERRORS CAN CAUSE IMPROPER AND DANGEROUS OPERATION. VERIFY PROPER OPERATION AFTER SERVICING.

65-01-00457

The appliance must be electrically connected and grounded in accordance with local codes or, in the absence of local codes, with the current NFPA 70-National Electric Code or CSA C22.1-Canadian Electrical Code.

Caution: Label all wires prior to disconnection when servicing controls. Wiring errors can cause improper and dangerous operation” and “Verify proper operation after servicing.”

Attention: Au moment de l'entretien des commandes, étiquetez tous les fils avant le débranchement. Des erreurs de câblage peuvent entraîner un fonctionnement inadéquat et dangereux.” “S'assurer que l'appareil fonctionne adéquatement une fois l'entretien terminé.

# GLASS FRAME ASSEMBLY REPAIR AND REPLACEMENT

**DO NOT** substitute other manufacturer's materials or components.

**DO NOT** operate unit with cracked, broken or missing glass.

**DO NOT** abuse the glass door by striking the glass, slamming the door shut, etc

## WARNING

Use only authorized parts and materials obtained from Johnson Gas Appliance Company when replacing defective or damaged glass.

## WARNING

Do not operate this appliance with the glass removed, cracked or broken. Glass should be replaced by a licensed or qualified person.

## TO REPLACE DAMAGED GLASS

1. Bend Glass Retainer Tabs up 90 degrees. Four tabs hold down the glass and gasket assembly.
2. Remove the damaged glass and gasket material. Clean the inner surface of the glass frame.
3. Assemble new gasket on glass edge starting with the bottom left corner. The adhesive on the gasket should make contact with the glass surface. Use tracer lines in gasket to determine where the glass should sit on the gasket surface.
4. Place glass and gasket assembly in glass frame and carefully bend down glass retainer tabs. Extra glass retainer tabs are provided should any originally used tabs break off.

The glass frame assembly and its individual components are available through Johnson Gas Appliance Company. Contact your dealer for more detailed ordering information.

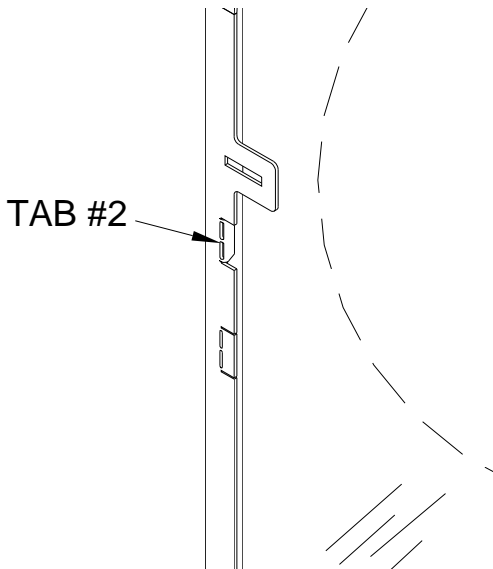

## GLASS FRAME ASSEMBLY # HA-106-00001 REPLACEMENT PARTS LIST

ITEM	PART NUMBER	DESCRIPTION
1	HA-106-00002	FRAME, WELDMENT, GLASS, FV34 ARCH
2	65-02-00103	GASKET, TADPOLE, 3/8" BULB, 3/4" TAIL
3	65-06-01378	GLASS, CERAMIC, FV34-ARCH

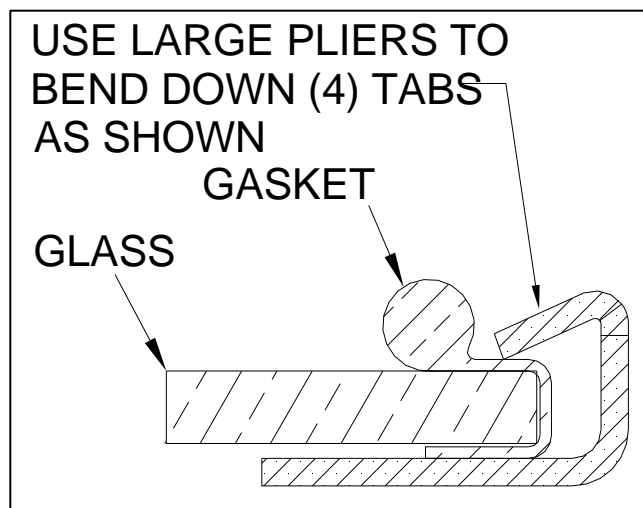
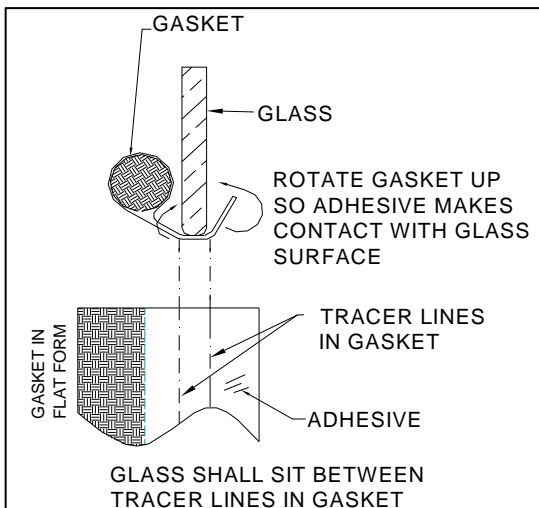

## Maintenance and Diagnostics Helpful Hints

### Components Location:

**Manual Shutoff Ball Valve:** A manual shutoff ball valve is located in the left air gap adjacent to the glass frame left edge. Use the glass latch tool to operate this ball valve.

**Main Gas Valve:** The main gas valve is located on the left side of the firebox. An inspection panel is provided on the left firebox wall that allows inspection of the gas valve, wiring and gas inlet connections.

**Ignition Control Module:** The ignition Control Module is mounted on the right side on the floor. Access to the Ignition Module is available through the Blower and Control Module Access panel.

**Ignition Control Module Main Wire Harness:** The main wire harness which connects the Ignition Module to the main gas valve, valve motor and rear burner solenoid valve runs below the firebox floor from the right side to the left side. Care must be exercised not to pull or tug on this harness which may result in breakage of connection terminals on either ends.

**Convection Blower:** The convection blower is mounted on the firebox right wall. Access to the convection blower is available through the Blower and Control Module Access panel.

**Accent Light:** The accent light is mounted in the firebox top center area. The accent light wire harness is run from the light housing to the right side and then down to the ignition control module.

**Master Switch and Sync Switch:** The Master switch and Sync switch are mounted on the right side bottom edge of the glass frame on a small metal plate which can be removed to replace defective Master switch or Sync switch.

**Rear Burner Air Shutter Control:** A rear burner air shutter control is located in the gap behind the Sync Switch. Operate the rear burner air shutter using the glass latch tool.

**Electrical Junction Box:** An electrical junction box is located on the right side of this appliance and is accessible through the Convection Blower and Control Module access panel.

**Gas Supply Inlet connection:** The main gas supply line enters this appliance on the left side and is accessible through the Gas Valve Inspection Panel.

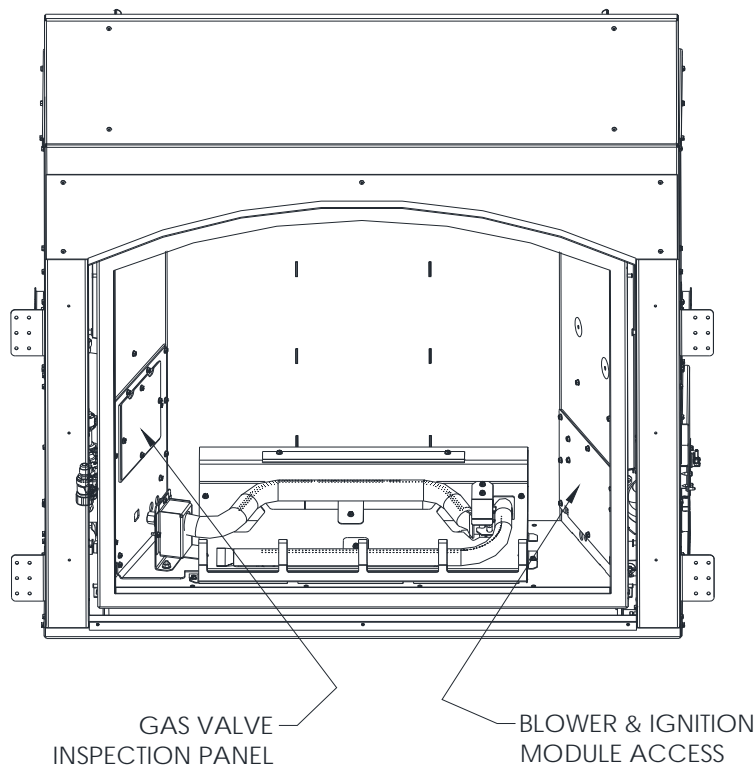

## TROUBLE SHOOTING THE FV34-ARCH FIREPLACE & MAINTENANCE INFORMATION

SYMPTOM	PROBABLE CAUSES	CORRECTIVE ACTION
1. Thin black coating (soot) forms on viewing glass.	A. Incorrect gas pressure B. Not enough combustion air C. Leaking Glass Gasket	Have gas supplier check for correct gas inlet pressure (7" W.C. Nat. Gas; 11" W.C. LP Gas). Check Glass Gasket for proper seal. Corners of glass gaskets cannot be bulging out. If glass gasket along top edge in the middle is white in color across entire thickness of gasket bulb, replace glass gasket. If sooting continues, open air shutter on burner (see "Gas Flame Adjustment" below). If sooting still continues, shut off unit and call Mendota service person. <b>NOTE:</b> To clean glass - remove glass and wipe glass with cloth or paper towel.
2. Humming or whistling coming from Fireplace.	A. Normal operating noise. B. Burr in gas inlet orifice(s)	Some noise is normal. It is caused by the gas supply flowing through the gas orifice. It is expected from any gas fireplace. Turning the Hi/Lo Knob on the control can reduce the noise. Turning down the flame will reduce the heat output of the unit. For Whistling noise, clean gas inlet orifice(s) openings.
3. A change in flame appearance or burner operation.	A. A change in gas pressure. B. Vent system restricted. C. Leaking Glass Gasket	Have your gas supplier check for correct gas 7" W.C. Nat. Gas; 11" W.C. LP Gas). Clean out carbon, spider webs, lint, etc. from shutter area. Logs and burner. Check Vent Cap's AIR INTAKE and Exhaust OUTLET ports. Check Glass Gasket for proper seal. Corners of glass gaskets cannot be bulging out. If glass gasket along top edge in the middle is white in color across entire thickness of gasket bulb, replace glass gasket.

### OVER FIRING OF BURNER

NEVER "over fire" units by adjusting gas pressure or drilling out the orifice to increase BTUH above nameplate specifications. Over firing can cause permanent damage to firebox and deterioration of parts and void warranty.

### MAINTAINING CORRECT PILOT-FLAME, PILOT OUTAGE & RELIGHTING

The pilot flame must be checked during initial installation and annually by a qualified Mendota Technician. This appliance utilizes Flame Rectification Technology. If the pilot flame is turned down too low, the flame sensor may not detect the pilot flame and the pilot light may not stay lit. Do not turn down the pilot light flame. The flame sensor rod may be coated with debris after a few months of use. It is important to clean the flame sensor rod using emery cloth if flame rectification problems are encountered after use for a few months. Environmental factors beyond the control of Mendota can cause flame rectification concerns.

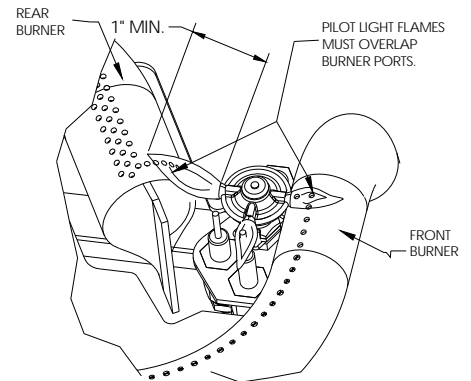

### CLEANING VIEWING GLASS

The viewing glass should be cleaned periodically. Exterior glass surface may be cleaned with cleaner as desired. To clean interior surface of glass - use soap and water. **CAUTION:** Do not use oven cleaner to clean glass. Clean the glass only when it has cooled to room temperature.

**NOTE:** Additives that are put in gas (both natural and propane) to make it smell can be harmful to glass and can leave a white film deposit on the glass. This deposit can be removed with cleaners such as KEL KEM "Polish Plus" (part # 65-06-00455) or comparable product (contact your dealer).

In some cases (especially when burning propane) additives can cause "crazing" or etching of the glass. This is not a common occurrence. However, any "crazing" or etching of the glass is not covered under the warranty. The solution may be to change propane suppliers.

### SOOTING

Sooting is caused by improper installation or air shutter operation. However, some small areas of soot deposits on log surfaces are deemed acceptable. If you observe large soot areas (larger than 1"x1") on log surfaces or signs of sooting on the door glass (usually a thin black film on the Fireplace viewing glass or on the outside of the home around the vent cap), the unit must be immediately turned off and the local Mendota dealer promptly informed. Mendota dealers will correct "sooting" problems, but Mendota and their dealers are not responsible for damage caused by excessive sooting that has not been immediately brought to their attention.

### OPERATION DURING POWER FAILURE

This fireplace is designed to operate during power outages. Blowers and the Accent Light will not function during power outages. However, all burners will continue to function normally.

### GAS SHUTOFF PROCEDURES

Locate Keyed Manual Gas Shutoff Valve installed adjacent to this Fireplace. Turn Key to OFF.

## MAINTENANCE

### **ANNUAL MAINTENANCE OF MENDOTA UNITS IS REQUIRED.**

The following procedures must be performed each year by a Mendota approved service person. NOTE: Any adjustments to burner, pilot or logs must be done by a qualified Mendota service person.

1. Clean all lint and dust build-up around the control. Inspect the condition of any wiring under the burner for melting or damage. Clean flame sensor rod/hook using emery cloth. Vacuum all burner ports and pilot assembly.
2. Remove logs & coals and clean away any foreign matter (lint, Carbon, etc.) on the burner and logs. Be sure the burner ports are "open". Clean the pilot and under side of the logs for any Carbon deposits. NOTE: Logs should be visually checked for Carbon "build-up". If carbon deposits are visible on logs, unit should be turned off and Mendota service person contacted. Be sure logs are re-installed per instructions.
3. Check condition of glass door gasket, gasket must seal tightly over firebox, Inspect gasket along top and sides of glass. If gasket at corners of glass are bulging outward or if gasket bulb along top edge or sides are discolored to a white color appearance through the whole thickness of the gasket bulb, then replace the gasket. White colored gasket bulb indicates exhaust leak through the discolored area and requires replacement of the glass gasket.

### **Periodic Inspections Required:**

1. Check to verify that the vent system and vent cap are open and free of blockage.
2. Before re-installing glass, have qualified service person check the operation of the pilot and cycle the burner per LIGHTING INSTRUCTIONS (see Owner's Manual). Be sure all items in LIGHTING and INSTALLATION "check off" lists are completed.
3. The viewing glass should be cleaned periodically. Exterior glass surface may be cleaned with cleaner as desired. To clean Interior glass surface, use Kel Kem "polish plus" (part # 65-06-00455) or comparable product. Do not use oven cleaner or abrasive cleaners to clean glass. Do not clean when glass is hot.
4. Periodic visual check of pilot flames is required. Pilot Flame must overlap Flame Sensor and burner ignition ports at all times. Especially for LPG applications, always verify visible pilot flame length is at least 1" long.
5. Periodic visual check of main burner's rear and front flames is required.

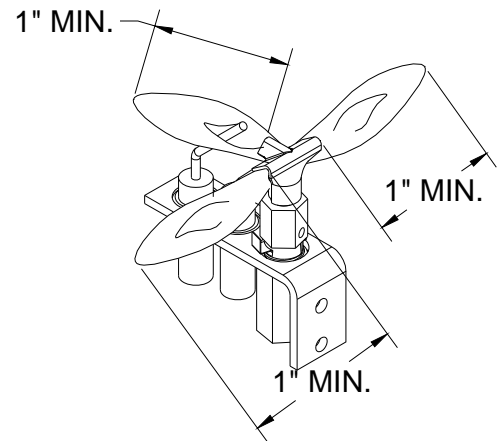

### **BURNER FLAMES GENERAL HEIGHTS REFERENCE DIAGRAM**

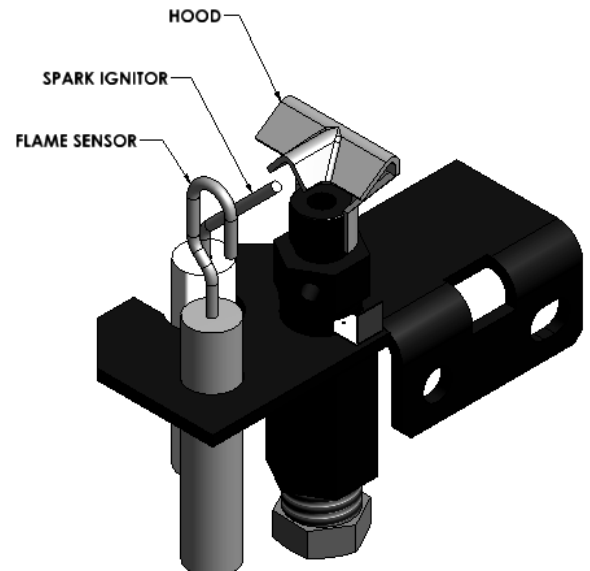

# NOTES



**MENDOTA WARRANTY QUALIFICATION & SERVICE REFERENCE FORM**

As a part of Mendota's on-going program of customer satisfaction, this Form verifies proper installation and operation. It is important as a reference for future service. It insures long life and trouble-free operation of Mendota fireplaces & stoves and qualifies the owner for Mendota's lifetime limited warranty. Owner should sign Form when completed and mail a copy along with Warranty Registration to Mendota. OPTIONALLY, PLEASE REGISTER AT OUR WEBSITE AT:

**<http://mendotahearth.com/gas-fireplace-and-stove-registration.php>**

HOME OWNER: \_\_\_\_\_ DEALER: \_\_\_\_\_  
ADDRESS: \_\_\_\_\_ ADDRESS: \_\_\_\_\_  
CITY/STATE/ZIP: \_\_\_\_\_ CITY/STATE/ZIP: \_\_\_\_\_  
SIGNATURE: \_\_\_\_\_ PHONE: \_\_\_\_\_  
MODEL #: FV34-ARCH-PF2 SERIAL #: \_\_\_\_\_ DATE INSTALLED: \_\_\_\_\_

Mendota direct vent fireplaces are sophisticated, hi-tech gas appliances. All installation and operating instructions must be carefully followed. This FV34-ARCH fireplace must be installed and serviced by a qualified Mendota approved service person.

- APPROVED VENT PIPES AND VENT CAP INSTALLED - Per Manual.  
Vent pipes must be fully twist-locked and leak proof.  
Check minimum and maximum vertical / horizontal and vent runs.  
1000° sealant must be used on inner joints at adjustable pipe sections.
- CHECK FOR PROPER CLEARANCES TO COMBUSTIBLES & VENT LOCATIONS - Per Manual
- INSTALL PROPER SIZE GAS LINES - CHECK FOR GAS LEAKS - Per Manual
- CHECK FOR CORRECT GAS PRESSURE AT MANIFOLD - Per Manual
  - a. 3.5 Inches Water Column Maximum - Nat. Gas (plus or minus 1/8")
  - b. 10.0 Inches Water Column Maximum - L.P. Gas (plus or minus 1/8")
- CYCLE BURNERS ON/OFF FOR PROMPT IGNITION - Per "LIGHTING INSTRUCTIONS"  
Burner must light IMMEDIATELY - Flame must travel promptly around "curve" & light burner.
- INSTALL LOGS AND ADJUST FLAME - Per Manual  
Proper pilot flame impingement on burner - Air shutter opening: 1/8" Nat. Gas – 1/4-1/2" LP  
Check that flame is "stable" and is not "lifting" off burner
- BRIEF OWNER ON OPERATION AND MAINTENANCE OF UNIT
  - Light Pilot  Operate Burner  Train on Remote Control Functions  Explain Thermostatic Functions

**WARRANTY REGISTRATION**

Your Name \_\_\_\_\_  
Address \_\_\_\_\_  
City \_\_\_\_\_ State \_\_\_\_\_ Zip \_\_\_\_\_  
Dealer (Place of Purchase) \_\_\_\_\_  
City \_\_\_\_\_ State \_\_\_\_\_ Zip \_\_\_\_\_  
Date of Purchase \_\_\_\_\_ Serial Number \_\_\_\_\_  
Purchaser's Signature \_\_\_\_\_

MENDOTA FV34-ARCH DIRECT VENT FIREPLACE

CUT OUT PAGE AND MAIL TO: JOHNSON GAS APPLIANCE CO., 520 E AVE. N.W., CEDAR RAPIDS, IOWA 52405

**PLEASE REGISTER AT OUR WEBSITE AT: WWW. <http://mendotahearth.com/gas-fireplace-and-stove-registration.php>**

TAPE SHUT



**JOHNSON GAS APPLIANCE COMPANY  
520 E AVENUE N.W.  
CEDAR RAPIDS, IA 52405**

# **MENDOTA EXTENDED PROTECTION AND LIMITED WARRANTY**

## **MENDOTA FV34-ARCH DIRECT VENT FIREPLACE**

Mendota Division of Johnson Gas Appliance Company, 520 E Avenue N.W. Cedar Rapids, Iowa 52405, extends this Extended Protection and Limited Warranty to the original purchaser of a Mendota FV34-ARCH Fireplace, which is limited and used under normal home conditions.

### **STANDARD WARRANTY:**

JOHNSON GAS APPLIANCE CO., MENDOTA DIVISION, WARRANTS THAT YOUR NEW MENDOTA FIREPLACE AND ALL ITS COMPONENTS ARE FREE FROM MANUFACTURING AND MATERIAL DEFECTS FOR A PERIOD OF ONE YEAR FROM THE DATE OF INSTALLATION. SUBJECT TO PROOF OF PURCHASE AND THE CONDITIONS AND LIMITATIONS OUTLINED, BELOW.

### **EXTENDED WARRANTY:**

THE MAIN BURNER ASSEMBLIES ARE WARRANTED FOR A PERIOD OF 2-YEARS TO THE ORIGINAL OWNER, FROM THE DATE OF PURCHASE. SUBJECT TO PROOF OF PURCHASE AND THE CONDITIONS AND LIMITATIONS OUTLINED, BELOW.

THE HEAT EXCHANGER, COMBUSTION CHAMBER AND OUTER SHIELD OF THE MENDOTA FV46 FIREPLACE ARE WARRANTED FOR 10-YEARS TO THE ORIGINAL OWNER. SUBJECT TO PROOF OF PURCHASE AND THE CONDITIONS AND LIMITATIONS OUTLINED, BELOW.

- 1) This new Mendota Fireplace must be installed & serviced by a competent, authorized service contractor. It must be installed and operated at all times in accordance with the installation and operating instructions furnished with the Fireplace. All adjustments to logs, coals or burner must be made by an authorized Mendota person. Any alteration, willful abuse, accident or misuse of the product shall nullify this warranty. This warranty does not cover glass or log breakage.

This limited warranty does not cover the cost of service calls, the cost of labor to remove or install parts covered by this limited warranty, freight or other transportation expenses, which may be incurred in connection with obtaining performances under this limited warranty. The remedy for damages as the result of any defects in this product which have been warranted herein is limited to replacement parts and does not include any incidental, indirect or consequential damages or expenses sustained in connection with the product, including damages to property, except as provided by law.

- 2) This warranty is non-transferable and is made to the original retail purchaser, provided the purchase was made through an authorized Mendota dealer.

Mendota is not responsible for any damage to or malfunction of the Fireplace unless caused by a defect in material or workmanship from normal home use. Damage caused by abuse, improper installation, improper servicing, and installation by unqualified personnel or breach of conditions of this limited warranty will excuse Mendota from performance of any part of this limited warranty. Mendota has the right to investigate and inspect the exact, original Fireplace and entire installation (without any alterations or tampering) in the event a claim is made to determine whether the claimed damage or malfunction was caused by abuse, improper installation or other cause outside this warranty. Mendota is not responsible for any repairs or material purchases that have not received prior written approval from Mendota.

NOTE: Minor warping of certain parts or discoloration is normal and is not a defect covered by this warranty. Major warping of parts can be caused by over-firing of your Mendota Fireplace. Over-firing above rated nameplate specification is as contrary to the manufacturer's instructions and may void this warranty.

This warranty may not be extended by our representatives or any third party in any manner. The company neither assumes, nor authorizes any third party to assume, on its behalf, any other liabilities with respect to the sale of this Mendota product.

- 3) Mendota may at its discretion, fully discharge all obligations of this warranty by refunding the wholesale price of the defective part(s).
- 4) All other warranties - expressed or implied - with respect to the product, its components and accessories, or any obligation/liabilities on the part of the company are hereby expressly excluded. Products made by other manufacturers, sold with the Fireplace or thereafter, are not covered by this limited warranty. The use of unauthorized components will make this warranty null and void.
- 5) It remains the full responsibility of the owner to operate this appliance within the guidelines provided in the Installation Manual and the Operating Instructions Manual accompanying this appliance. Further, the owner shall bear full responsibility to enforce clearances to combustibles requirements and cautioning others about hot glass surfaces and hot metal surfaces. Owner, by operating this appliance, accepts that this is a heat producing appliance which has glass and steel parts that are hot enough to cause severe burns. Owner accepts that this appliance requires close monitoring of children and vulnerable individuals who are in the vicinity of this appliance when this appliance is in operation. Mendota does not assume or accept any liability claims for burns or other physical or material damages resulting from touching hot glass surfaces and hot metal surfaces that are part of this appliance or other adjacent object such as hearth pads and mantels that may heat up during operation of this appliance.

This warranty shall be effective only if the original purchaser of the Mendota appliance is registered with Mendota Division within thirty (30) days of the date of purchase. Such registration or the failure to register shall not be deemed to create any obligation or liability by the manufacturer and this warranty with its conditions and limitations shall be the only procedure for obtaining any rights against the manufacturer and expresses the sole obligation and responsibilities of the manufacturer which are offered to the original purchaser and accepted upon purchase of the appliance.

Mendota Division, reserves the right to make changes at any time without notice, in design, material, specifications, prices and the right to discontinue styles and products.

Some states do not allow the exclusion of limitation of incidental or consequential damages or limitations on how long an implied warranty lasts, so the above limitation or exclusion may not apply to you. This warranty gives you specific legal rights and you may also have other rights which vary from state to state.

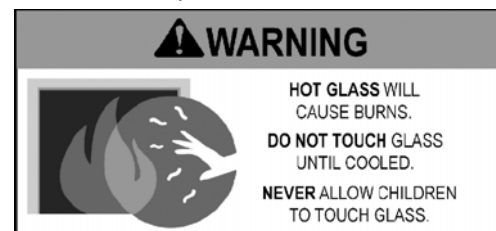

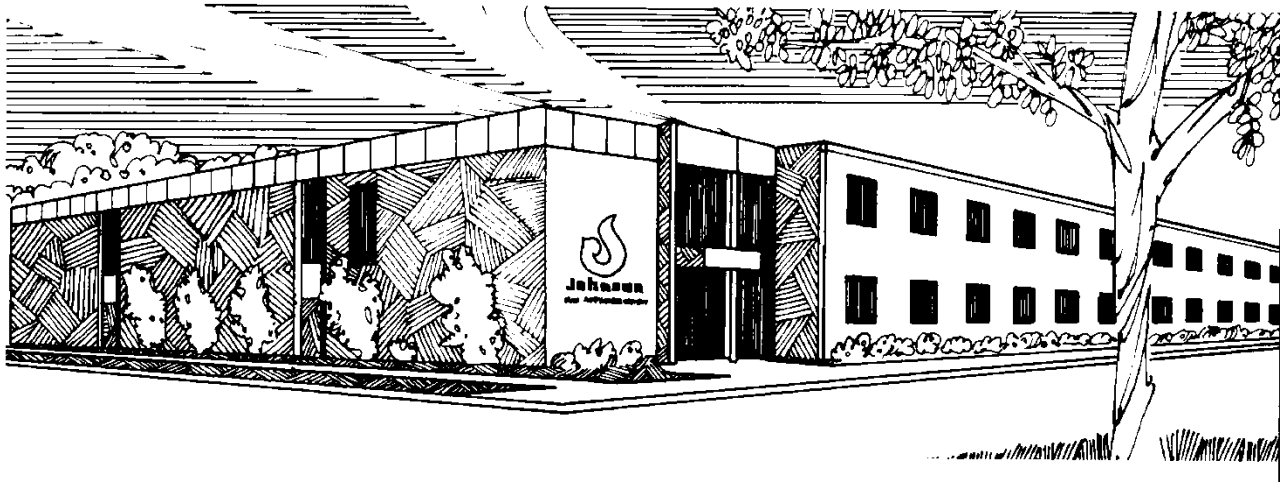

Johnson Gas Appliance Company  
520 E Avenue N.W. - Cedar Rapids, IA 52405  
Mendota Hearth Division

WEBPAGE: [www.johnsongas.com](http://www.johnsongas.com) or [www.mendotahearth.com](http://www.mendotahearth.com)